

SMD ELECTRO-MAGNETIC TRANSDUCER

1	Part number	SMT-1411A-03032
2	Rated Voltage (V)	3
3	Operating Voltage (V)	2~4.5
4	Resonant Frequency (Hz)	3200
5	Coil Resistance (Ω)	19 \pm 4
6	*Sound Output at 10cm (dB)	\geq 90
7	*Current Consumption (mA)	\leq 80
8	Operating Temperature ($^{\circ}$ C)	-20 ~ +70
9	Storage Temperature ($^{\circ}$ C)	-30 ~ +80
10	Weight (g)	1
11	Housing Material	LCP
12	RoHS	Yes

*Applying rated voltage (Resonant frequency, 1/2 duty, Square wave)

DIMENSIONS (UNIT: mm)

Tolerance: \pm 0.5mm Except Specified

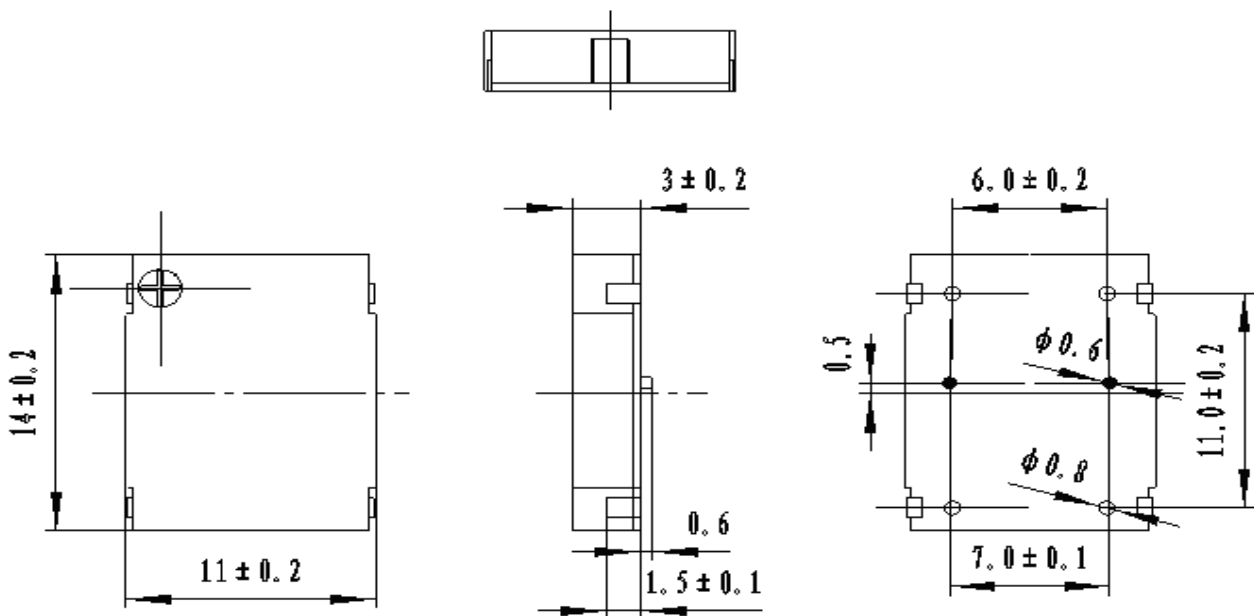

TEST METHOD:

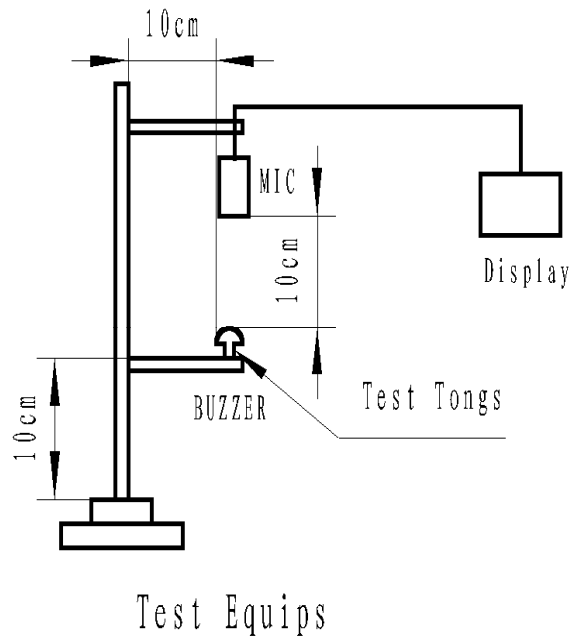
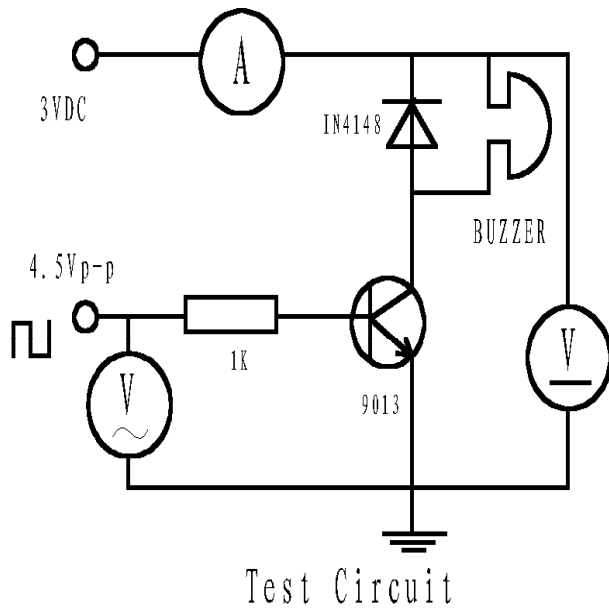

FREQUENCY RESPONSE:

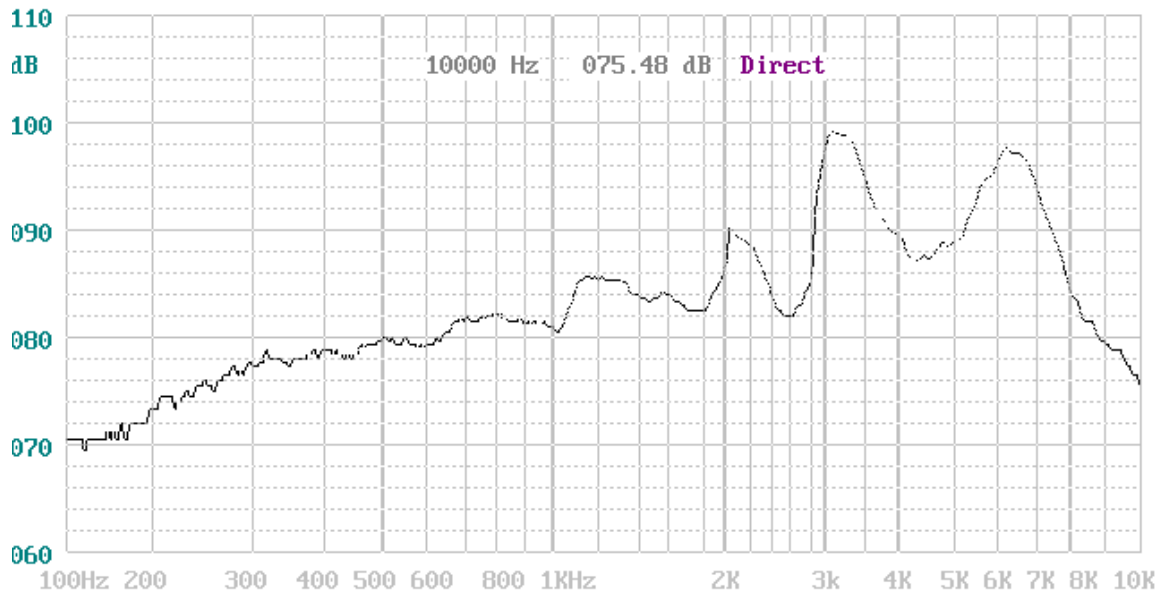

SANCO ELECTRONICS CO., LTD

RELIABLY TEST:

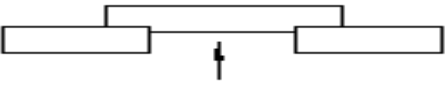
NO.	ITEM	TESTING CONDITION	VARIANCE AFTER TEST
1	High temp. storage life	The part shall be capable of withstanding a storage temperature is +80°C for 120 hours	After the test the part shall meet specifications without any degradation in appearance and performance except SPL shall be initial value ± 10dB or more.
2	Low temp. storage life	The part shall be capable of withstanding a storage temperature is -30°C for 120 hours	
3	Temp. cycle	Total 5 cycles, 1 cycle consisting of -30±2°C, 30 minutes 20±5°C 15 minutes 80±2°C, 30 minutes 20±5°C 15 minutes	
4	Humidity Test	40±2°C, 90~95% RH, 120 hours	
5	Vibration test	The part shall be subjected to a vibration cycle is 10Hz in a period is 1 minute. Total peak amplitude shall be 1.52mm(9.3g). The vibration test shall consist of 2 hours per plane in each three mutually perpendicular planes for a total time of 6 hours.	
6	Shock	Sounder shall be measured after being applied shock (980m/s ²) for each three mutually perpendicular directions to each of 3 times by half sine wave.	
7	Solder ability	The part leads (pins) shall be immersed in molten solder maintained at 235+5°C for a period of 2.0+0.5 seconds	Ninety-five percent (95%) coverage with a continuous coating of bright new solders.
8	Solder heat resistance	The part leads (pins) shall be immersed in molten solder maintained at 250±10°C for a period of 30 seconds.	After the test part shall meet specifications without any degradation in appearance and performance.
9	Lead pull	The part shall be pushed with a force of 9.8N for 10±1 seconds behind the part. 	After the test part shall meet specifications without any degradation in appearance and performance.
10	Recommended temp. Profile for Reflow Oven	Shown in Fig.1	
<p>Warranty:For a period of one year from date of manufacture under normal operations.</p>			

Recommended Temp. Profile for Reflow Oven (Fig.1)

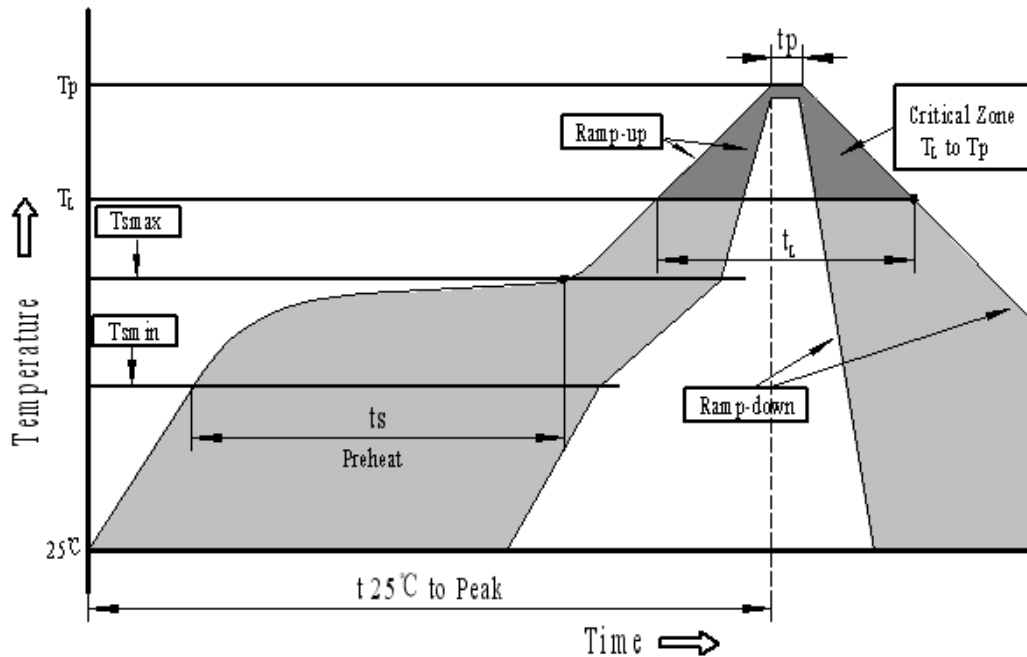

Profile Feature	Pb-Free Assembly
Average ramp-up rate(T_L to T_p)	3°C/second max.
Preheat	
-Temperature Min.(T_{smin})	150°C
-Temperature Min.(T_{smax})	200°C
-Temperature Min.(t_s)	60~180 seconds
T_{smax} to T_L	
-Ramp-up Rate	3°C/second max.
Time maintained above:	
- Temperature(T_L)	217°C
-Time(T_L)	60~150 seconds
Peak temperature(T_p)	245°C+0/-5°C
Time within 5°C of actual Peak temperature (t_p)	6 seconds max.
Ramp-down Rate	6°C/second max.
Time 25°C to Peak Temperature	8 minutes max.

PACKING:

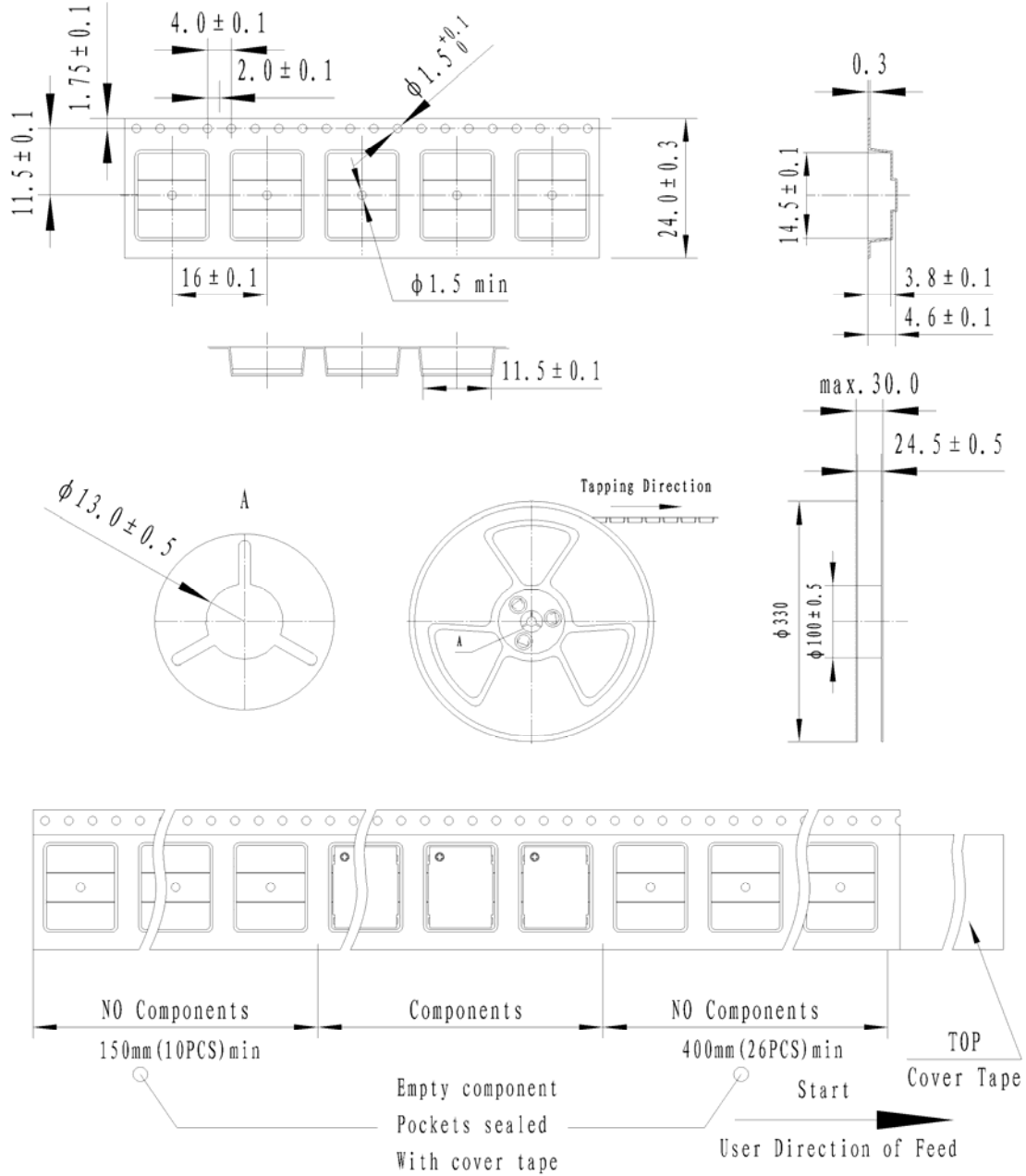

SANCO ELECTRONICS CO., LTD

PACKING:

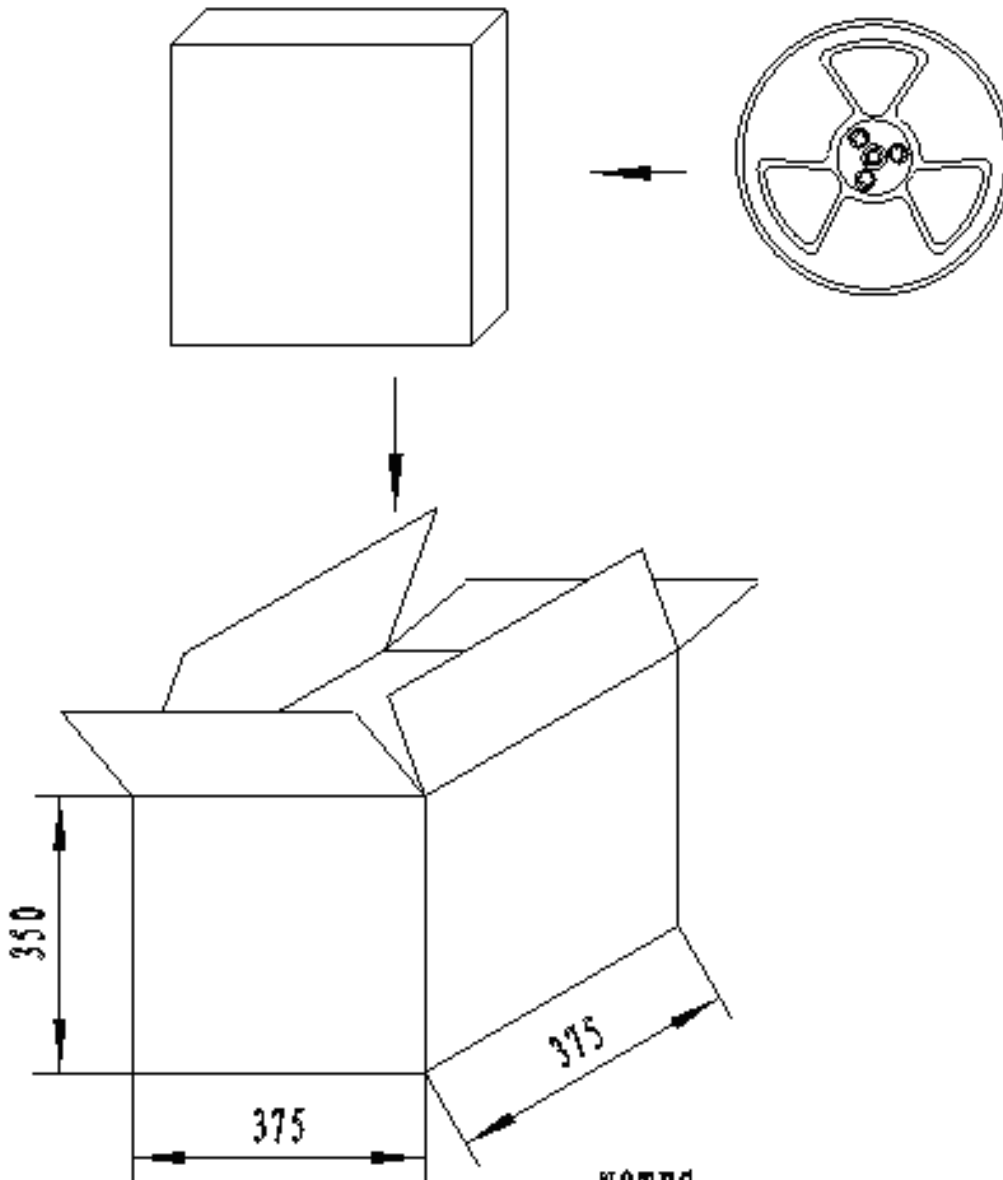

NOTES:

1. 750 PCS per box
2. Total 10 boxes per carton
3. Total 7500 PCS carton