

SPECIFICATION FOR APPROVAL

承 认 书

Description : **Magnetic Transducer**

Vender's Part No. : **SMT-3020A-03040**

Customer's. Part No. :

Serial No. : **SAN-2057**

Version No. : **1.1**

CUSTOMER'S APPROVED SIGNATURE		

NINGBO SANCO ELECTRONICS CO., LTD.

Rm724, No.22 Lane38, Furong Road, Ningbo Hi-tech park, Ningbo China

TEL: +86-0574-83851068

FAX: +86-0574-83851096

E-Mail: sales@sancoelectronics.com

Http: //www.sancobuzzer.com

Approved By	Checked By	Made By

A. SCOPE

This specification applies magnetic buzzer, **SMT-3020A-03040**

B. SPECIFICATION

No.	Item	Unit	Specification	Condition
1	Oscillation Frequency	Hz	4000	Vo-p=1/2duty , square wave
2	Operating Voltage	Vo-p	2 ~ 4	
3	Rated Voltage	Vo-p	3	
4	Current Consumption	mA	MAX. 120	at Rated Voltage
5	Sound Pressure Level	dB	MIN. 72	at 10cm at Rated Voltage
6	Coil Resistance	Ω	12±3	
7	Operating Temperature	°C	-20 ~ +70	
8	Storage Temperature	°C	-30 ~ +80	
9	Dimension	mm	3.0 x 3.0 x H2.0	See appearance drawing
10	Weight (MAX)	gram	0.1	
11	Housing Material		LCP(Black)	
12	Leading Pin		Tin Plated Brass(Sn)	See appearance drawing
13	Environmental Protection Regulation		RoHS	

C. APPEARANCE DRAWING

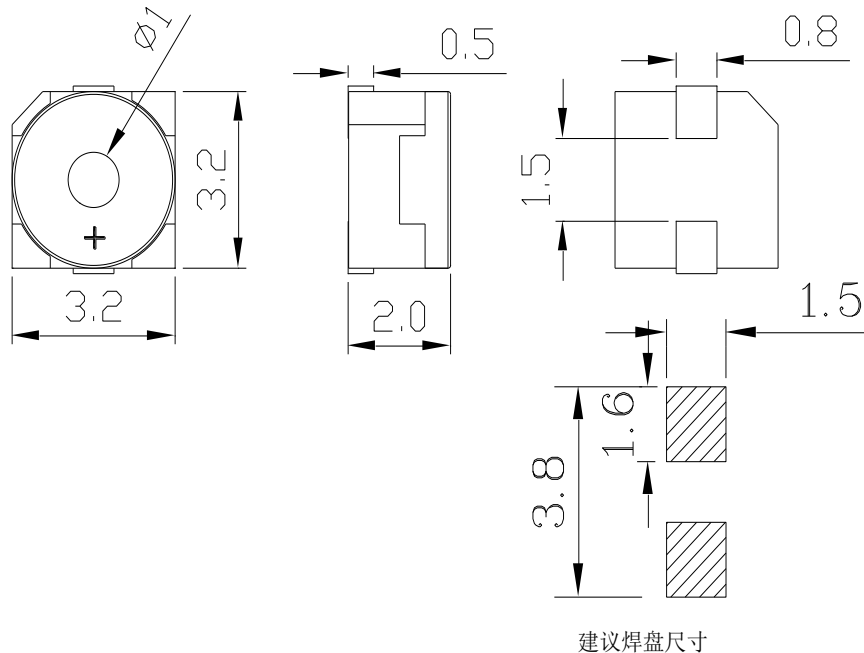

Tol : ± 0.3

Unit: mm

D. TESTING METHOD

Standard Measurement conditions

Temperature: $25 \pm 2^\circ\text{C}$ Humidity: 45-65%

Acoustic Characteristics:

The oscillation frequency, current consumption and sound pressure are measured by the measuring instruments shown below

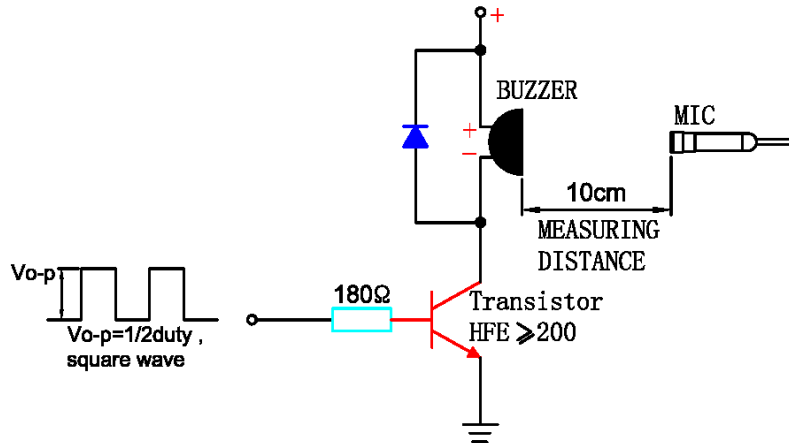

In the measuring test, buzzer is placed as follows:

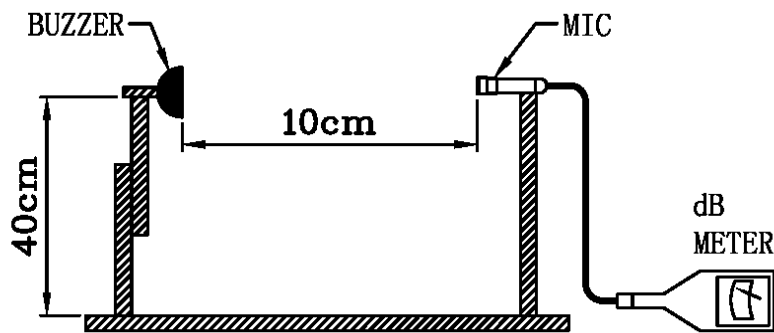

E. Typical Frequency Response Curve

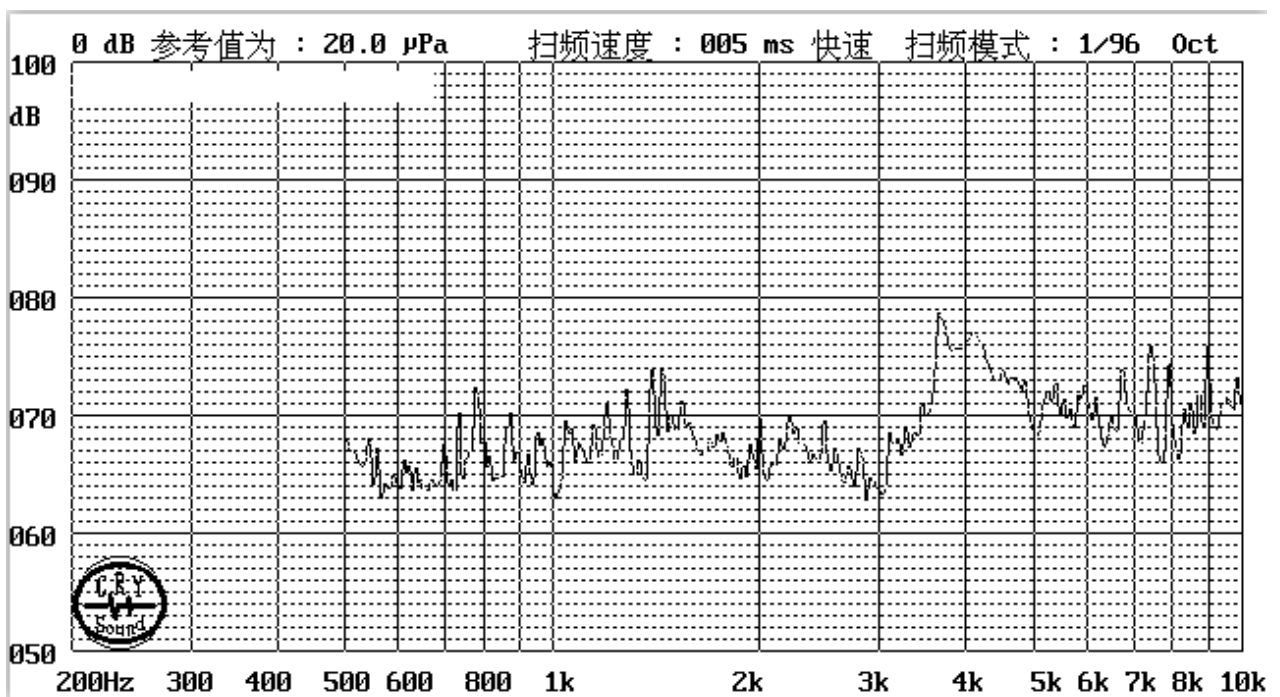

F. Recommend Driving Circuit

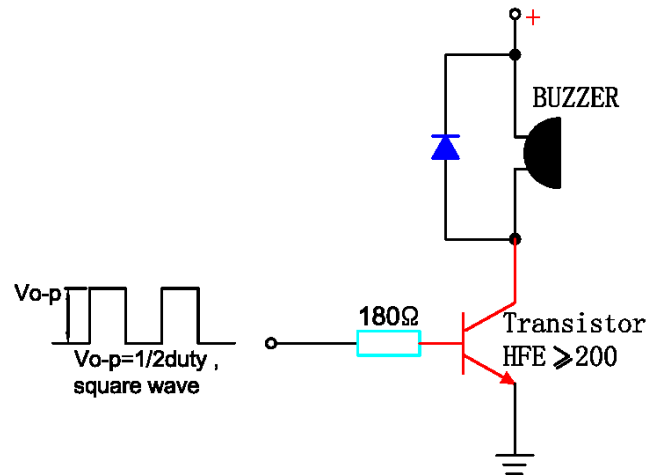

The base current I_b should be high enough so that it saturates the collector current of the transistor with the CB load.

G. Soldering Condition

(1) Recommendable reflow soldering condition is as follows

(Reflow soldering is twice)

Note: It is requested that reflow soldering should be executed after heat of product goes down to normal.

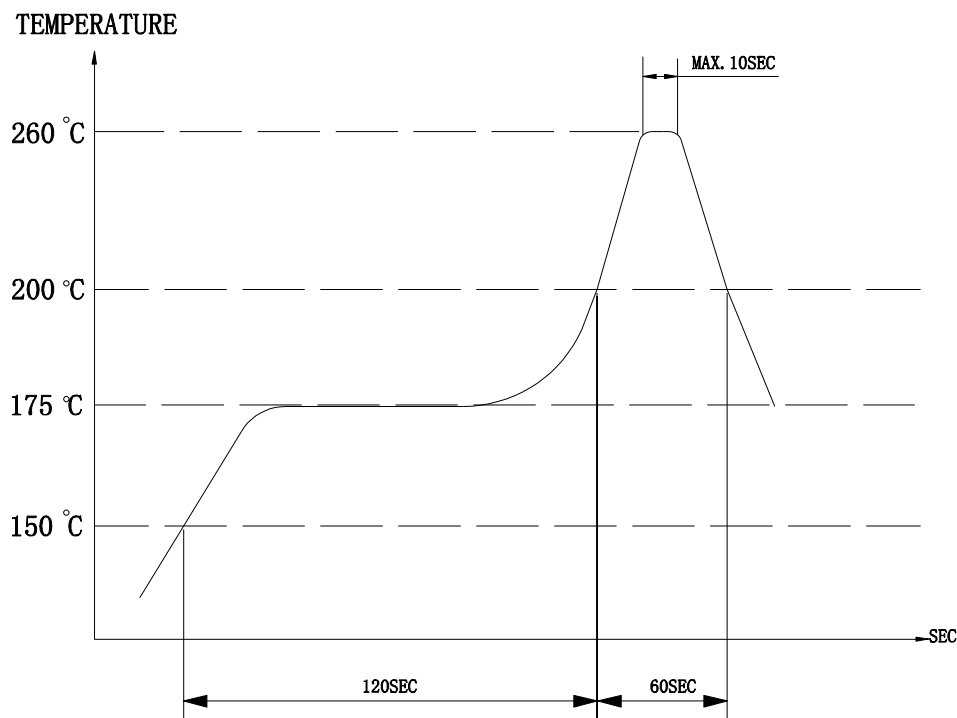

Heat resistant line

(Used when heat resistant reliability test is performed)

(2) Manual soldering

Manual soldering temperature 350 °C within 5 sec.

H. RELIABILITY TEST

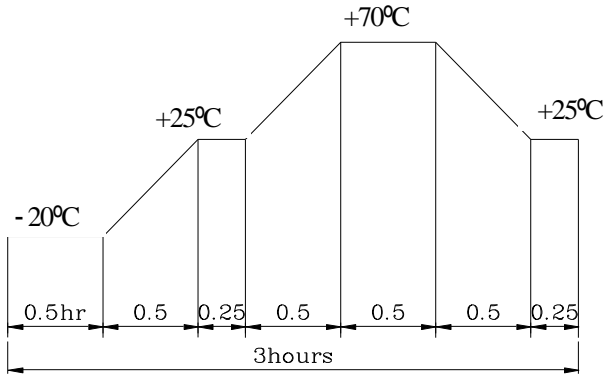
NO.	ITEM	TEST CONDITION AND REQUIREMENT
1	High Temperature Test (Storage)	After being placed in a chamber with 80 2°C for 96 hours and then being placed in normal condition for 2 hours. Allowable variation of SPL after test: 10dB.
2	Low Temperature Test (Storage)	After being Placed in a chamber with -30 2°C for 96 hours and then being placed in normal condition for 2 hours. Allowable variation of SPL after test: 10dB.
3	Humidity Test	After being Placed in a chamber with 90-95% R.H. at 40 2°C for 96 hours and then being placed in normal condition for 2 hours. Allowable variation of SPL after test: 10dB.
4	Temperature Cycle Test	<p>The part shall be subjected to 5 cycles. One cycle shall be consist of :</p>  <p>The diagram shows a temperature cycle profile over 3 hours. It starts at -20°C for 0.5 hours, then ramps up to +25°C in 0.5 hours, holds at +25°C for 0.25 hours, ramps up to +70°C in 0.5 hours, holds at +70°C for 0.5 hours, ramps down to +25°C in 0.5 hours, holds at +25°C for 0.25 hours, and finally ramps down to -20°C in 0.5 hours. The total duration is 3 hours.</p> <p>Allowable variation of SPL after test: 10dB.</p>
5	Drop Test	Drop on a hard wood board of 4cm thick, any directions ,6 times, at the height of 75cm . Allowable variation of SPL after test: 10dB.
6	Vibration Test	After being applied vibration of amplitude of 1.5mm with 10 to 55 Hz band of vibration frequency to each of 3 perpendicular directions for 2 hours . Allowable variation of SPL after test: 10dB.
7	Solderability Test	Lead terminals are immersed in rosin for 5 seconds and then immersed in solder bath of +300 5°C for 3 1 seconds . 90% min. lead terminals shall be wet with solder (Except the edge of terminals).
8	Terminal Strength Pulling Test	The force of 9.8N(1.0kg) is applied to each terminal in axial direction for 10 seconds. No visible damage and cutting off.

TEST CONDITION.

Standard Test Condition	:	a) Temperature : +5 ~ +35°C	b) Humidity : 45-85%	c) Pressure : 860-1060mbar
一般测试条件	:	a) 温度 : +5 ~ +35°C	b) 湿度 : 45-85%	c) 气压 : 860-1060mbar
Judgment Test Condition	:	a) Temperature : +25 ± 2°C	b) Humidity : 60-70%	c) Pressure : 860-1060mbar
争议时测试条件	:	a) 温度 : +25 ± 2°C	b) 湿度 : 60-70%	c) 气压 : 860-1060mbar

I. PACKING STANDARD

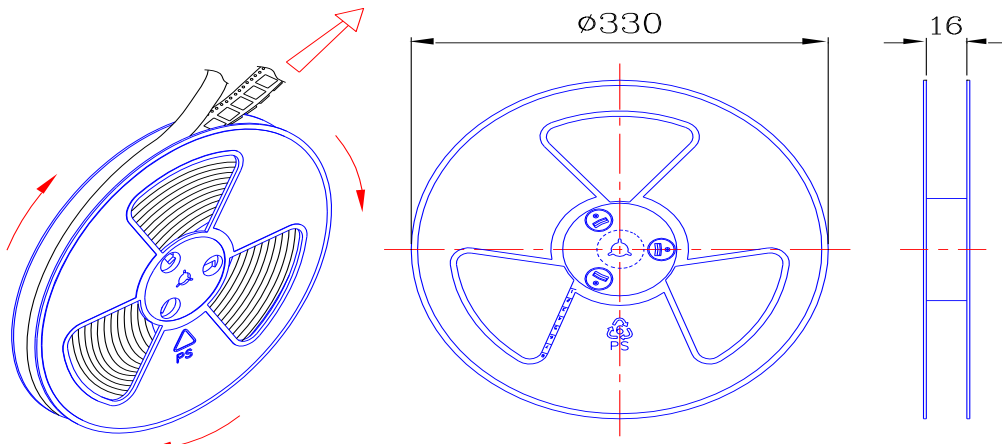

1 Reel : 3000PCS

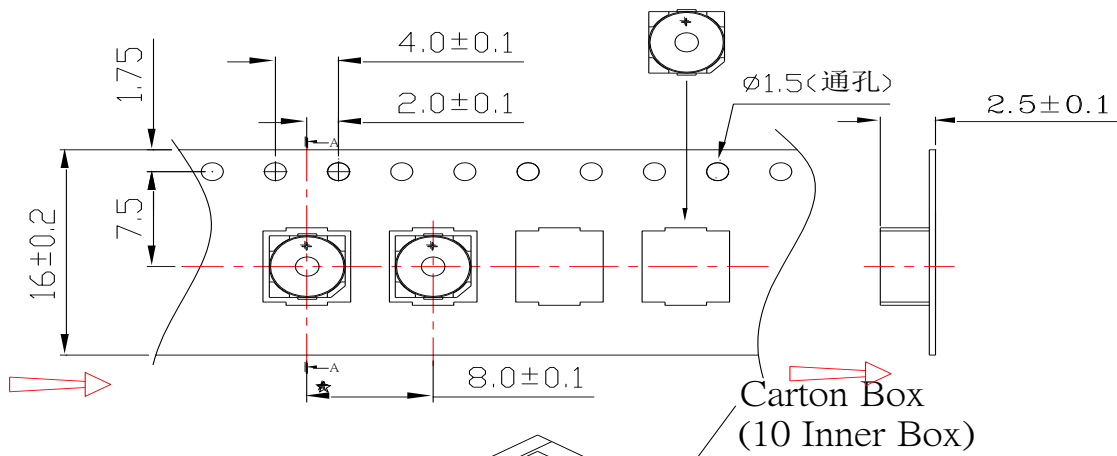

Carton Box
(10 Inner Box)

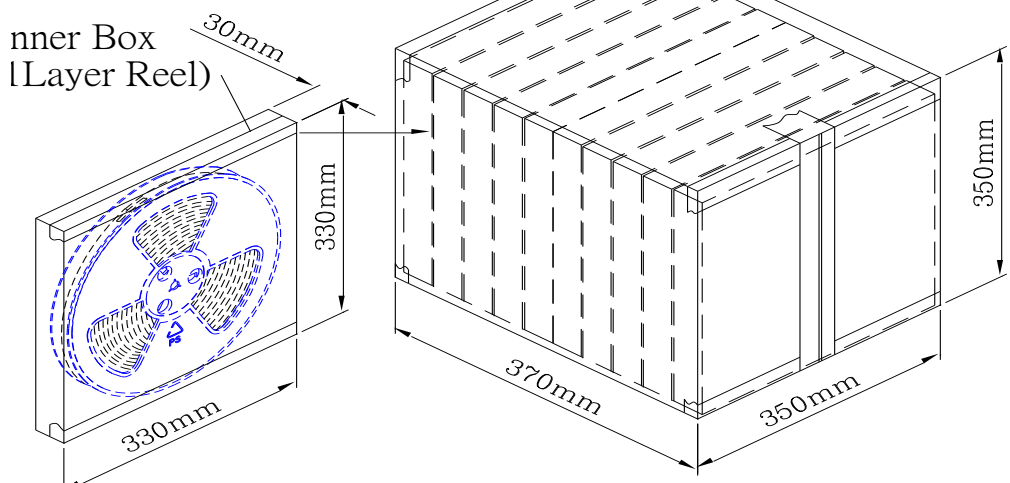

Inner Box	330mmx330mmx30mm	1x3000PCS=3000PCS
Carton Box	350mmx350mmx370mm	10x3000PCS=30,000PCS