

HSF



ROHS

Notes:

- 1: Material:
Spring: stainless steel SUS304
- 2: Plating:
Spring: 50~80u' Ni
Contact area: 3u' Au over 50~80u' Ni
- 3: Electrical:
Rated Current&Voltage: DC 1A, 12V
Contact Resistance: 50 mΩ Max. at working height.
- 4: Mechanical:
Force: 60~80g at working height.
Durability: 1000 cycles (min)
- 5: Work Temperature:
Withstanding Highest Temperature: 280°C
Operational Temperature: -20°C ~ + 70°C

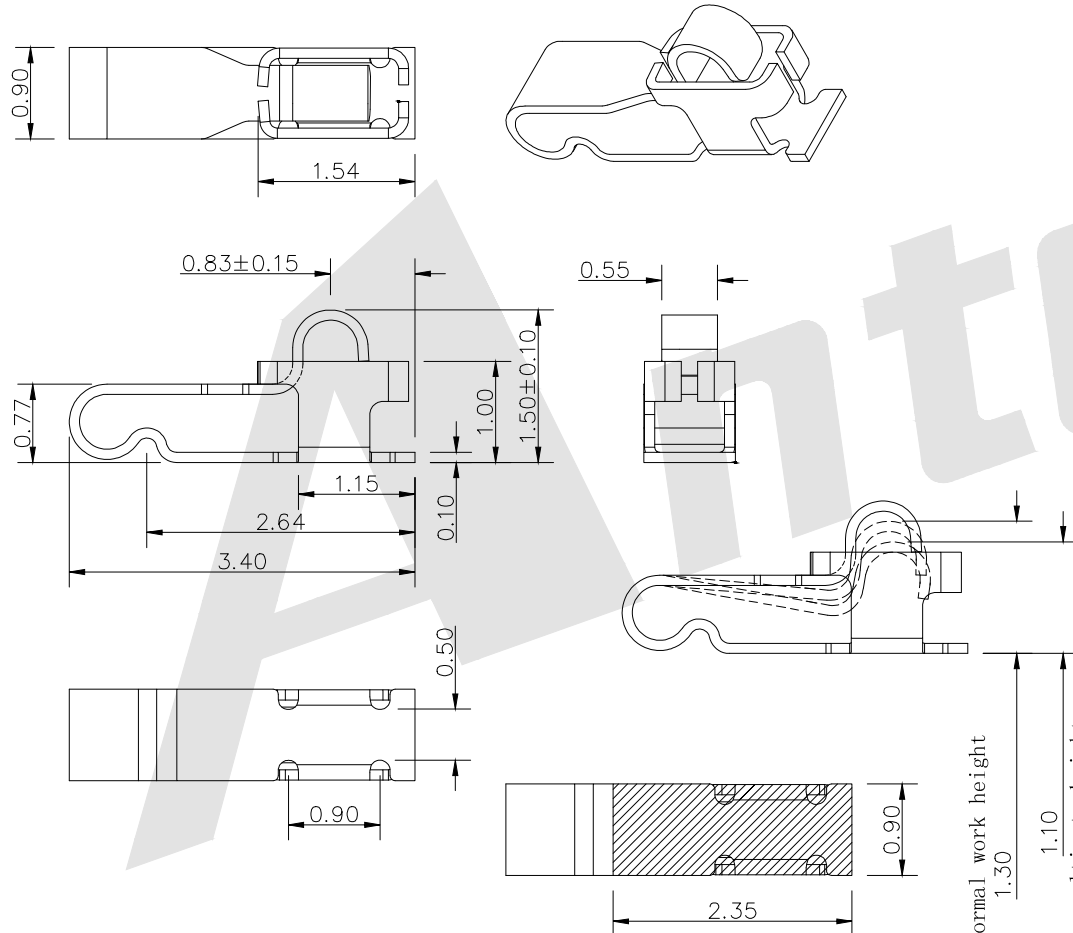

SF - 034 - X - X - 03
① ② ③ ④ ⑤

- ① Series No. :
SF: Spring Finger
- ② Length:
034: 3.4mm
- ③ Packing Method:
A: Tray R: Tape & Reel B: Bag
- ④ Plating
A: 1u" Au Plated over 50~80u Ni
B: 3u" Au Plated over 50~80u Ni
C: Sn Plated over Ni
- ⑤ Serial Number:
03

RECOMMENDED PCB LAYOUT

Unless Otherwise specified tolerance
X. ±0.35 X.XX: ±0.20
X.X: ±0.25 X.XXX: ±0.15

Antenk ANTEK ELECTRONICS CO., LTD
Http://www.antenk.com
E-mail: sales@antenk.com

SCALE: As Shown UNIT: mm
DRAW ZLA DATE 01/04/2022
CHECK BobYang DATE 01/04/2022

TITLE:
Spring Finger L=3.4MM

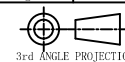

DRAWING NO: SF-034-X-X-03

PRODUCT NO: SF-034-X-X-03

REV	DESCRIPTION	DATE
1		
2		
3		
4		
5		