

HSF

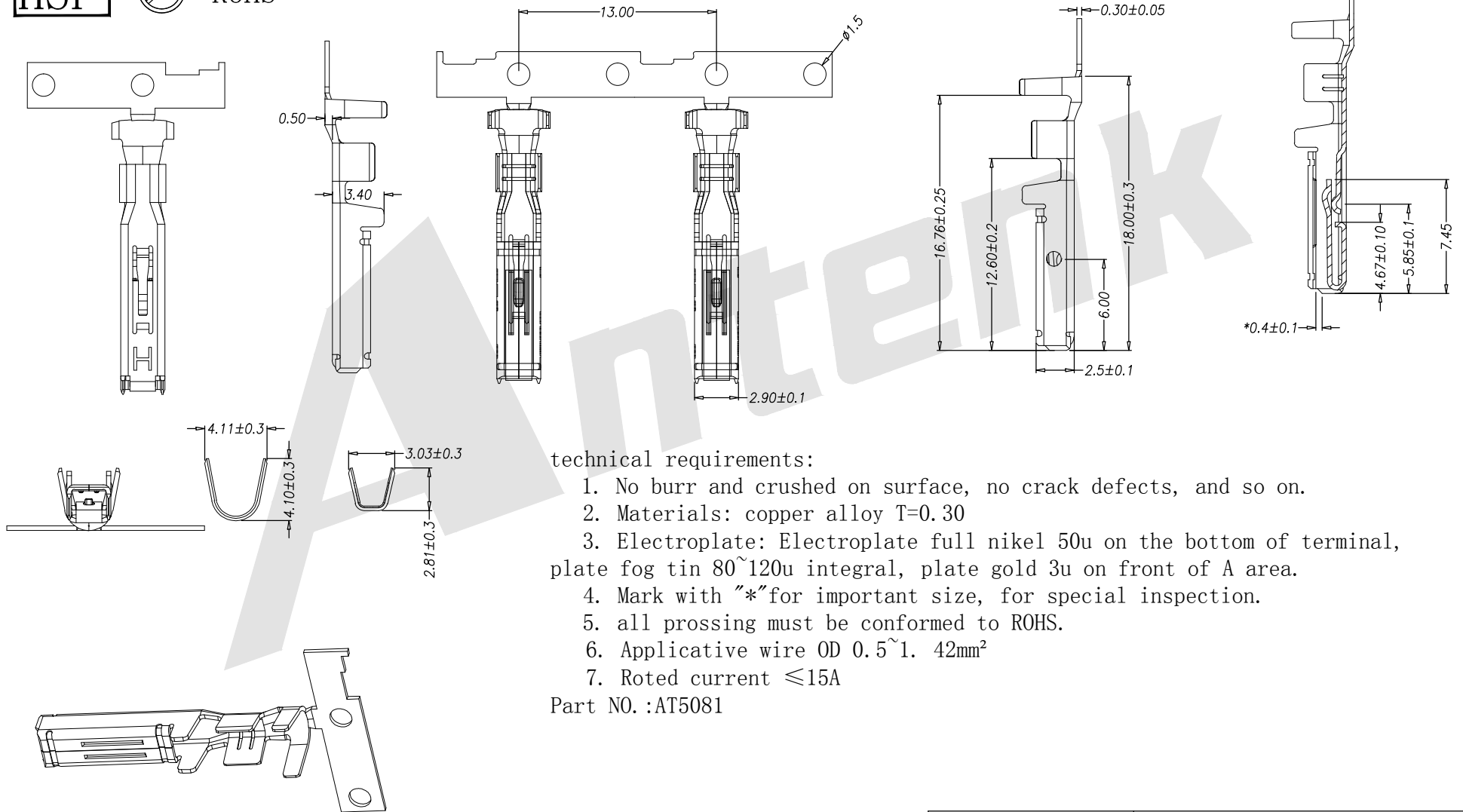

ROHS



technical requirements:

1. No burr and crushed on surface, no crack defects, and so on.
2. Materials: copper alloy T=0.30
3. Electroplate: Electroplate full nikel 50u on the bottom of terminal, plate fog tin 80~120u integral, plate gold 3u on front of A area.
4. Mark with "*" for important size, for special inspection.
5. all pressing must be conformed to ROHS.
6. Applicative wire OD 0.5~1. 42mm²
7. Roted current ≤15A

Part NO. :AT5081

Unless otherwise specified tolerance
 X. ±0.35 X.XX: ±0.20
 X.X: ±0.25 X.XXX: ±0.15



ANTENK ELECTRONICS CO.,LTD
 Http://www.antenk.com
 E-mail:sales@antenk.com

SCALE: As Shown UNIT: mm

DRAW: TMX DATE: 13/01/2022

CHECK: BobYang DATE: 13/01/2022

TITLE:
 5.08mm dynamic crimp terminal

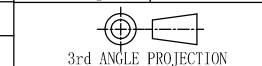

DRAWING NO: AT5081

PRODUCT NO: AT5081

REV	DESCRIPTION	DATE
		11/09/2020