

ELECTRO-HYDRAULIC PROPORTIONAL PILOT RELIEF VALVES

◆ 编号说明 HOW TO ORDER

1	2	3	4	5
EDG	01	H	D2	DL

1 系列名称: VALVE SERIES
EDG=ELECTRO-HYDRAULIC PROPORTIONAL PILOT RELIEF VALVES

2 称呼口径: SUBPLATE MOUNTING SIZE
01=1/4"(6mm)ISO CETOP3 DIN NG 6 NFPAD03
03=3/8"(9mm)ISO CETOP5 DIN NG 10 NFPAD05

3 压力调整范围: ADJUSTMENT PRESSURE
B: 5-70bar C: 10-160 bar H: 12-250 bar

4 电磁线圈类型: TYPE OF COIL
A1: AC 110 50HZ D1: DC12
A2: AC 220 50HZ D2: DC24
R1: RF 110 60HZ/50HZ
R2: RF 220 60HZ/50HZ

5 接线型式: WIRING TYPE
接线盒式: LW TERMINAL BOX TYPE
插头型: DL PLUG IN CONNECTOR

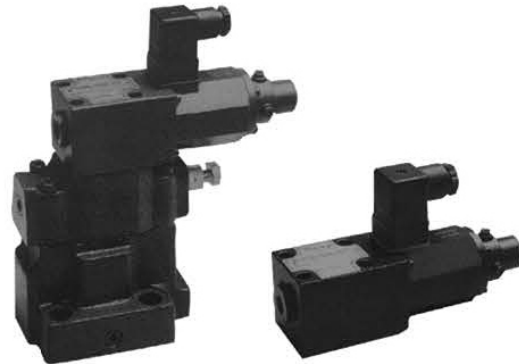

EBG-03

EDG-01

◆ 动作形式: CONTROL PORT (S)

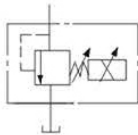

◆ 性能表 SPECIFICATION

型号 Model Number	压力 (bar) Pressure	流量 (l/min) Flow-Rate	额定电流 (mA) Rated Current	线圈电阻 (Ω) Coil Resistance	重量(kg) Weight
EDG-01	250	2	B:800 C:900 H:950	10	2.0
EBG-03		100			5.6
EBG-06		200			6.3
EBG-10		400			10.0

◆ 外型尺寸图 DIMENSIONS

EDG-01

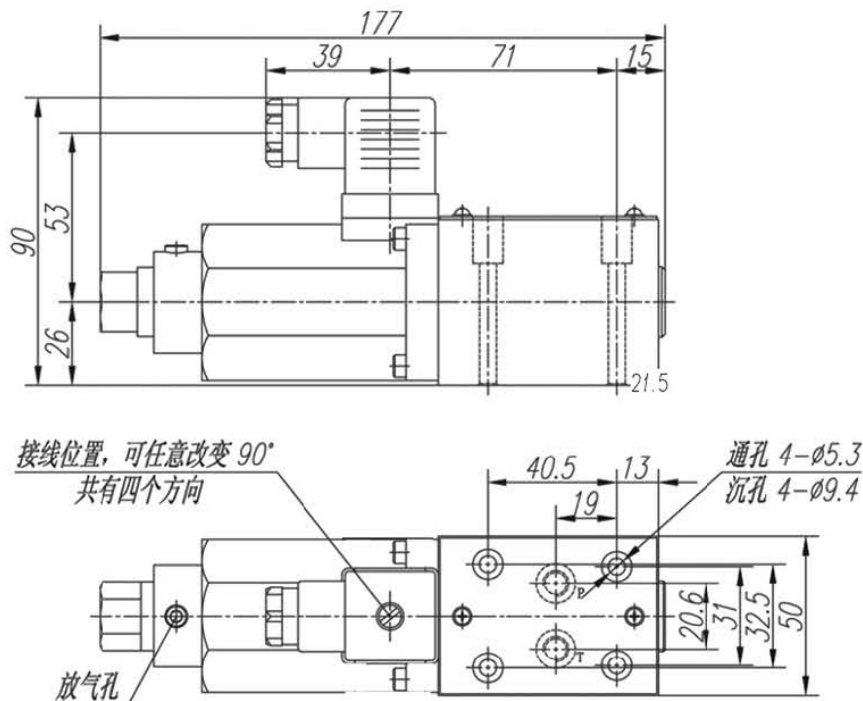

◆ 外型尺寸图 DIMENSIONS

EBG-03

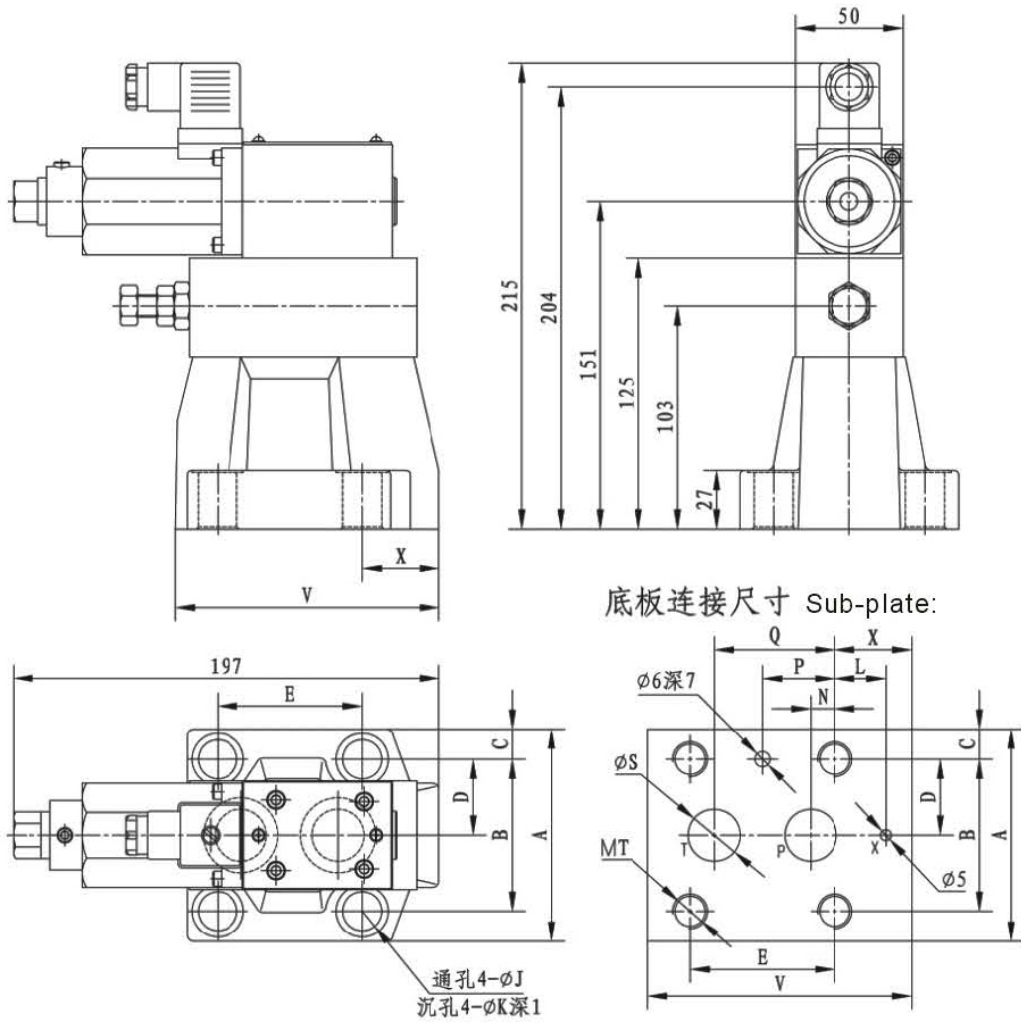

型号 Model Number	A	B	C	D	E	J	K	L	N	P	Q	S	T	V	X	安装螺钉
EBG-C3	78	53.8	12	26.9	53.8	14	21	0	22.1	22.1	47.5	12	12	105	25.7	4-M12×45
EBG-C6	98	70	14	35	66.7	18	25	23.8	11.1	33.4	55.6	22	16	122	36.5	4-M16×50