

ELECTRIC STEERING MOTOR

User manual (V1.5.3)



JINANKEYA ELECTRON SCIENCE AND TECHNOLOGY CO.,LTD.
(2022-05-07)

I. Overview

1.1 Motor Parameter

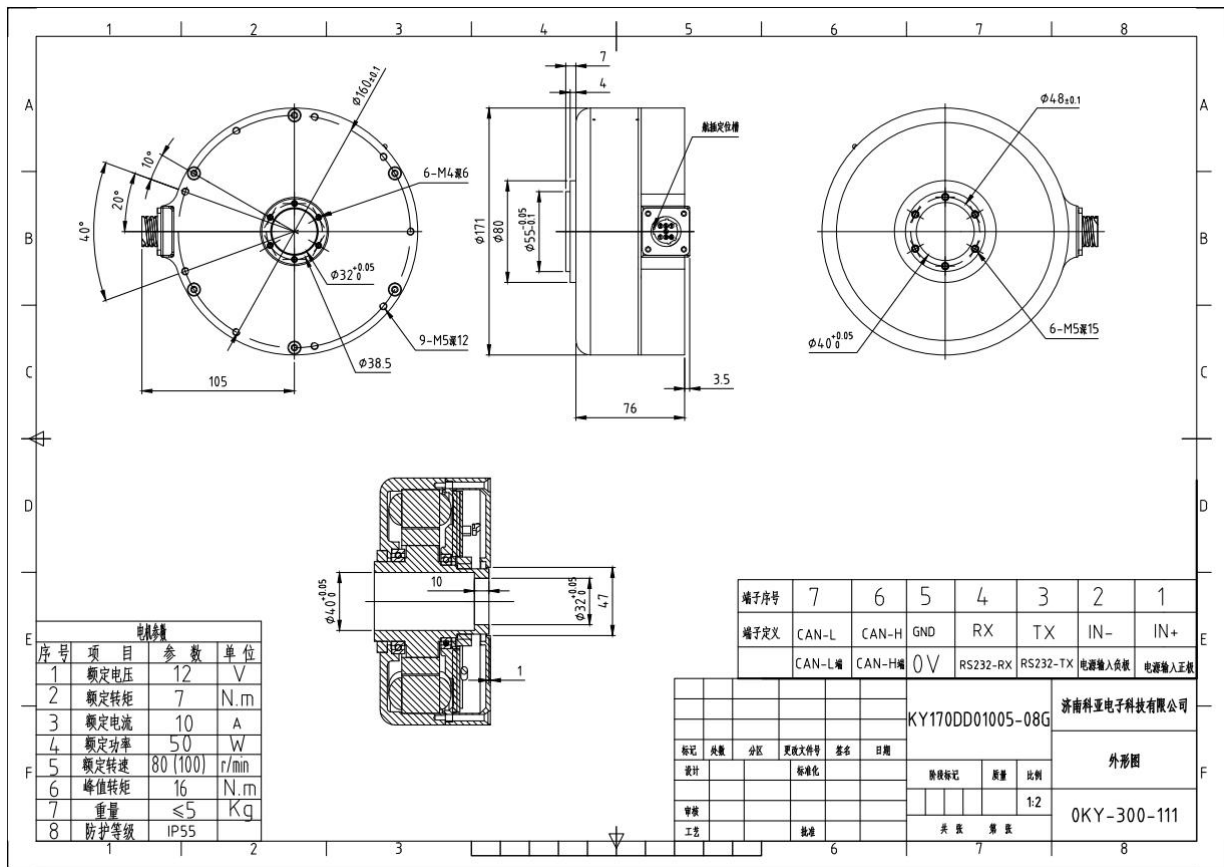

1.2 Specification

- DC working power +7V~32VDC
- Continuous current 10A, maximum peak current 20A
- Rated torque 7N.m, peak torque 16N.m
- Rated speed 80rpm - 100rpm (adjustable)
- Control signal: RS232, CAN2.0
- Working mode: speed mode, position mode.

Notice: When you use CAN, the motor support speed mode and position mode.

When you use R232, the motor support speed mode only.

1.3 Operation Condition

1.3.1 Power supply:

- Rated working power: 12VDC (factory setting 12VDC, if you need 24VDC, you can modify the motor configuration)

-
- Limit power supply range: 7--32VDC
 - It can provide instantaneous current overload capability of 2 times continuous current

1.3.2 Feedback component:

- Linear encoder.

1.3.3 Working environment:

- Operating temperature: -25~55°C (based on environment temperature);
Storage temperature: -35~65°C (based on environment temperature);
- Humidity: 5%--90%RH, condensation (25°C)
- Protection level: IP55.
- Insulation performance: input to the chassis DC600V, leakage current 0.07mA. The insulation resistance is 20 MΩ or more.
- Three-proof requirements: meet the requirements of three defenses (dust, moisture, salt spray).
- Vibration requirements: Frequency 5Hz ~ 25Hz, amplitude 3mm, 0.09g.
Frequency 25Hz~200Hz, amplitude 1.47mm, 116g.
Horizontal, vertical, and longitudinal directions are 30 min in each direction.
- Cooling method: natural cooling

II. Functional Technical Indicators

2.1 Main Function

- Working mode: Speed mode, position mode

Notice: When you use CAN, the motor support speed mode and position mode.

When you use R232, the motor support speed mode only.

- Feedback: Linear encoder.
- Control: RS232, CAN
- Fault LED indicator
- Can be controlled by CAN bus networking
- Realize motor speed control and data reading through RS232
- Internal temperature monitoring of drive
- Overcurrent and overload protection

- Overvoltage and undervoltage protection
- Temperature protection
- Locked-rotor and over speed protection
- Motor short circuit protection

2.2. Working Mode Configuration Table

Operating mode	Control instruction		Feedback component
Speed mode	RS232	CAN	Linear encoder
Position mode	CAN		Linear encoder

2.3. Technical Parameters

Parameter	Label	Parameter value	unit
Voltage	U	7-32	VDC
Max continuous current	I_c	10	A
Max peak current	I_{max}	20	A
PWM switching frequency	f_{pwm}	10	kHz
Output encoder power supply	+5V _{out}	5	VDC
	I_{cc}	100	mA
Under voltage	V _u	7 (adjustable)	V
Over voltage	V _o	32(adjustable)	V
Operating temperature	Industrial grade (standard product)	-25 ~ +55	°C
	Military grade	-40 ~ +65	
Storage temperature	Industrial grade (standard product)	-35 ~ +65	°C
	Military grade	-55 ~ +85	

III. Port Description

3.1. Interface Definition

Port	Definition	Description	Recommend wire
1	IN+	Power input +	16AWG
2	IN-	Power input -	16AWG
3	TX	RS232—TX	18AWG
4	RX	RS232—RX	18AWG
5	GND	GROUND	18AWG
6	CAN-H	CAN-H	18AWG
7	CAN-L	CAN-L	18AWG

TX, RX, GND:

RS232 interface, to achieve command control, as well as parameter settings, operating state commissioning, etc.

CAN-H, CAN-L: CAN interface

Drive internal already provided 120 Ω terminal resistance, do not need to add other terminal when use.

IN+ 、 IN- :

Because the vehicle requires long power cable, when the current is large, the voltage drop more due to the line loss. We recommend below cable specification:

Cable length (m)	Cabel diameter (mm ²)	Allowable Continue Amps
1-3	2.5	<17A
3-4.5	4	<25A

Note: When the motor “undervoltage alarm”, there may be the following reasons:

- (1) The battery is aging, and the internal resistance of the battery will increase after a long time of use, thereby reducing the battery's discharge capacity.
- (2) The steering hydraulic pump is aging, the flow valve is blocked, etc., which causes the steering resistance to increase and the motor current to increase.
- (3) The cable diameter is too thin, the voltage drop more, and when the torque is large, the voltage is pulled down, causing the driver to detect undervoltage.

3.2. Serial Port Connection

Using high-speed standard serial cable, DB9 plug meets the label definition:

Driver label	RS232 cable
TX	2
RX	3
GND	5

IV. Operating Instructions

4.1. The auto steering motor software Description

4.1.1 Configuration instructions

- Servo controller parameters can be set by the software.
- The software communicates with the control through RS232, and the baud rate is 115200bit.
- The software is developed under the .NET environment. XP systems need to have .NET 4.0 installed.

4.1.2 The software instructions

4.1.2.1 Double click the icon

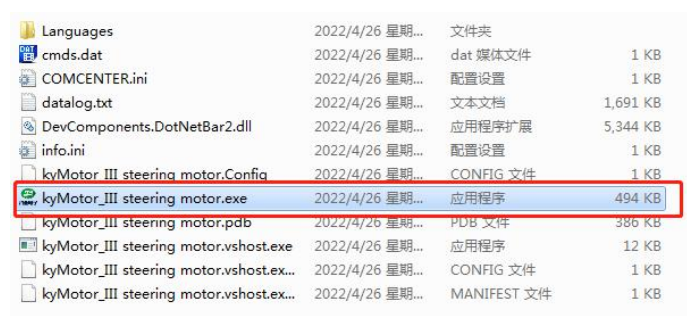

File Name	Date Modified	Type	Size
Languages	2022/4/26 星期...	文件夹	
cmds.dat	2022/4/26 星期...	dat 媒体文件	1 KB
COMCENTER.ini	2022/4/26 星期...	配置设置	1 KB
datalog.txt	2022/4/26 星期...	文本文档	1,691 KB
DevComponents.DotNetBar2.dll	2022/4/26 星期...	应用程序扩展	5,344 KB
info.ini	2022/4/26 星期...	配置设置	1 KB
kyMotor_III steering motor.Config	2022/4/26 星期...	CONFIG 文件	1 KB
kyMotor_III steering motor.exe	2022/4/26 星期...	应用程序	494 KB
kyMotor_III steering motor.pdb	2022/4/26 星期...	PDB 文件	386 KB
kyMotor_III steering motor.vshost.exe	2022/4/26 星期...	应用程序	12 KB
kyMotor_III steering motor.vshost.ex...	2022/4/26 星期...	CONFIG 文件	1 KB
kyMotor_III steering motor.vshost.ex...	2022/4/26 星期...	MANIFEST 文件	1 KB

4.1.2.2 Please select the software version “Servo”, click “Start”, If the communication is successful, the interface will read the control parameters, while the LED on the upper left will flash green, indicating that the parameters are communicating successfully.



4.1.2.3 Open the configuration interface, select “170 三代” and click the “Connect” button in the lower left corner to establish a connection between the software and the controller.



4.1.2.4 If you want run the motor via software, please open below page, and you can drag the slide to adjust the motor direction and speed.

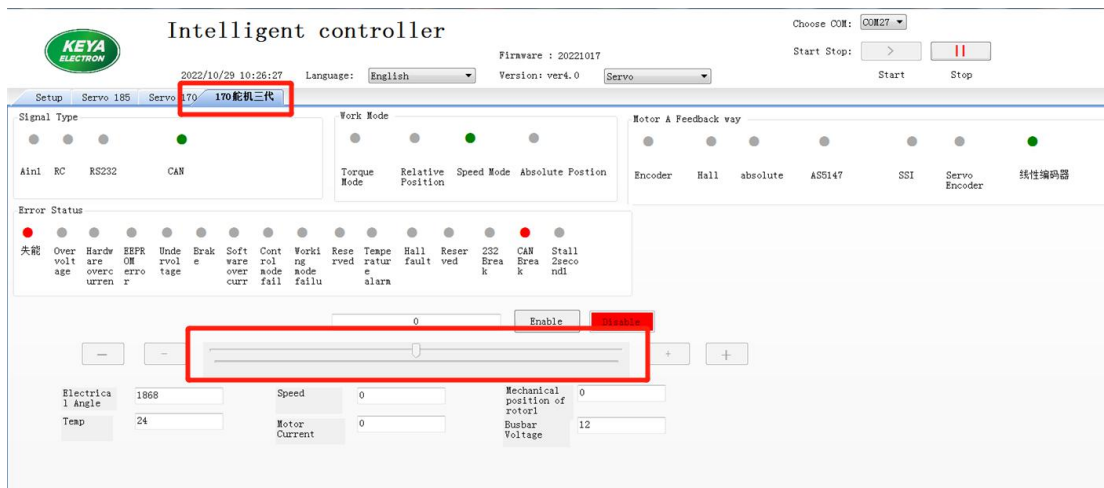

4.1.2.4 The RAM in the red box can be modified. The left side of the red box is the controller parameter, and the right side of the red box is the data in the E²ROM. In the correct case, the three data are consistent (equal).

As the software data is continuously scanned, when modifying the data, modify it quickly and click the "Write" button.

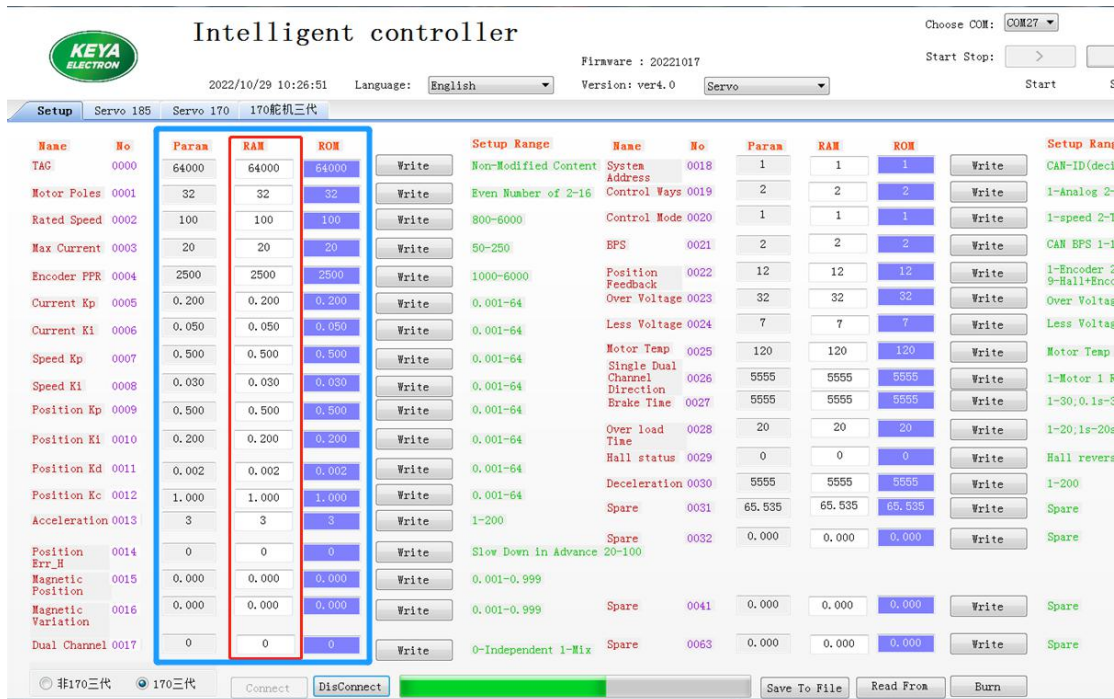

4.1.2.5 For example, if you want modify the number of encoder lines from 4800ppr to 4900ppr, the E² ROM data is 48000, please write 49000 in the RAM, and click "Write" button quickly. Confirm that 49000 is no longer changing. Same steps for other parameters, multiple parameters can be modified at the same time.

4.1.2.6 Click the "Program(Burn)" button at the bottom right. Program the data in RAM to E2ROM. Note: The programming process takes 3-5 seconds.

4.1.2.7 The "Program(Burn)" button turns red, indicating that data is being programmed. Please wait and observe the data. Until it remind "Programed successfully". Then the three datas(RAM, ROM, Param) in blue block are consistent, indicating that the ROM data is programed into the controller.

4.1.2.8 At this point, the modification of the control parameters is completed. Click the "Disconnect" button and click the "Exit" button.

4.1.2.9 Re-power the controller. (Note: No matter whether the configuration is modified or not, it must be powered off and reset to start normally)

4.1.2.10 When programming the configuration for multiple motors, you can "save a modified configuration to a file" and then "read from a file" to download to another motor.

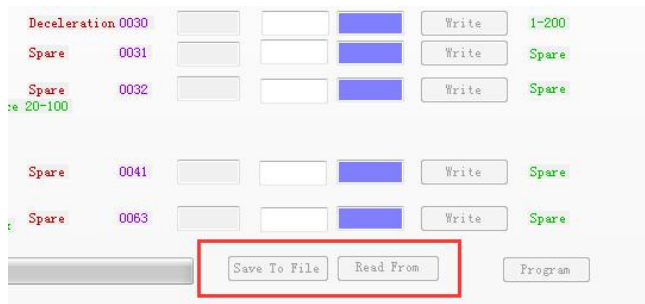

4.1.3 Parameter function description

0000 Identifier. when the system is connected, identify the software communication or serial port control. (Don't need modify)

0001 The number of motor poles (this motor is 32 poles)

0002 Rated motor speed (set to 80)

0003 Motor maximum current (Don't need modify)

0004 The number of encoder lines, his parameter is invalid.

0005 Kp parameter of controller current loop PI control (typical value 0.2)

Can be modified appropriately.

0006 Ki parameter of controller current loop PI control (typical value 0.02)

Can be modified appropriately.

0007 Kp parameter of controller speed loop PI control (typical value 0.5)

Can be modified appropriately.

0008 Ki parameter of controller speed loop PI control (typical value 0.005)

Can be modified appropriately.

0009-0012 Position loop PID control parameters

0013 Acceleration time. "5" means the acceleration time from 0rpm to rated speed is 0.5s.

0015 Zero position compensation of magnetic encoder

0016 Zero position compensation of rotary encoder

0018 Controller system address, or node number of control.

This parameter is used in the CAN, CANOpen, and EtherCAT buses.

For example: set the data to 1, then the ID in CAN bus: 0x0600000 + controller system address, it will be (0x06000001)

0019 Control signal selection

2. CAN open control; 3. RS232

0020 Control mode selection, including speed control, position control

1.Speed control,

3.Absolute position control, refer to the CAN bus protocol

4.Relative position control, refer to the CAN bus protocol

0021 CAN bus baud rate selection (Factory setting is 250K)

1.125k 2.250k 3. 500k 4. 1M

0022 Position sensor selection

12. Linear encoder (线性编码器)

Other parameters: spare

4.2 Indicator Description

4.2.1 Status indicator (RED light): Observe the status of the controller according to the blinking frequency of the indicator.

Number of flashes	Definition	Cause of issue
1	Working normally	Disability state
2	Over voltage	Supply voltage is over 32V(adjustable)
3	Hardware overcurrent protection 22A	Overcurrent protection caused by motor short circuit and field tube damage
4	EEPROM error	Data saving error
5	Less voltage	Supply voltage is lower than 7V(adjustable)
6	brake	Turn on the brake signal
7	Software overcurrent protection (software set protection value)	The phase current reaches the software setting protection value for 1 second to stop output.
8	Control mode failure	Control mode selection error
9	Working mode failure	Speed, position working mode not selected or wrong
10	Speed loss protection	Actual speed exceeds 25% of rated value
11	Temperature alarm	The temperature above 85 °C
12	Hall error	Motor Hall is off or malfunctioning

13	Reserved	Reserved
14	232 break	232 mode, no 232 signal input
15	CAN break	CAN mode, no CAN signal input
16	Blocking for 2 seconds	Motor stalled 2s protection

4.3.2 Enable indicator (BLUE)

In any control mode, the red indicator light will go out after the drive is enabled.

The indicator light is always on when the controller disabled.

4.3 CAN Instruction

4.3.1 General Configuration

- CAN bus protocol baud rate 250Kb
- CAN bus ID with extended ID
- Sending data format: low before, high later (hexadecimal)
- According to the CANOpen format, the data adopts the query mode.
- According to the CANOpen format, there is a fixed heartbeat and send related data.
- The watchdog detects the line-off period of 1000ms (speed command is sent continuously, the interval must not exceed 1000ms)
- Query data returns are hexadecimal data, which need to be converted into decimal data.

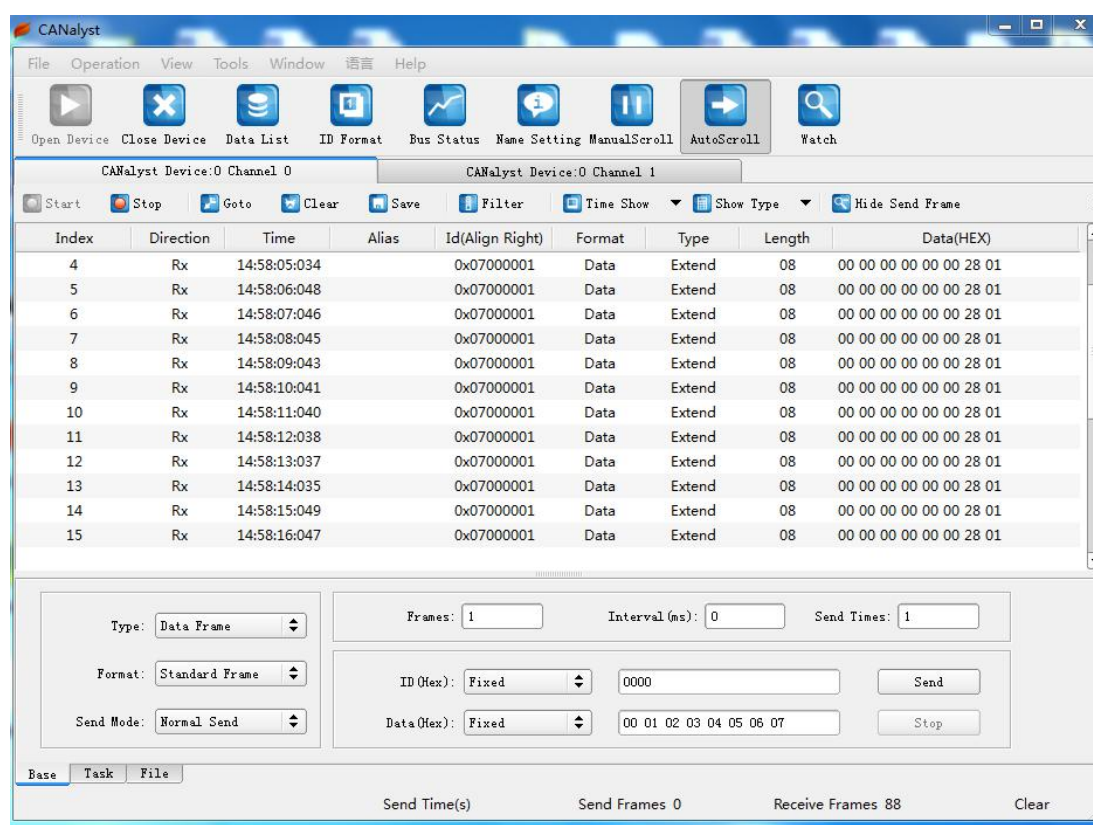

4.3.2 CAN bus instruction

Note 1: The controller ID is a decimal number in the configuration software, and the CAN software is a hexadecimal number.

Example: 1. The configuration software sets the controller ID to 1, and the CAN software ID is 06000001 (extension ID).

2. The configuration software sets the ID to 112, and the CAN software ID is 06000070.

Note 2: ID of sending data: 0x0600000 + controller ID (hexadecimal)

ID of returned data: 0x0580000 + controller ID (hex)

ID of heartbeat data: 0x0700000 + controller ID (hex)

Enable: 23 0d 20 01 00 00 00 00

Return ID: 0x0580000 + controller ID (hexadecimal)

Data 60 0d 20 00 00 00 00 00

Disable: 23 0c 20 01 00 00 00 00

Return ID: 0x0580000 + controller ID (hexadecimal)

Data 60 0c 20 00 00 00 00 00

Speed control: 23 00 20 01 DATA_L(h) DATA_L(l) DATA_H(h) DATA_H(l)

Return ID: 0x0580000 + controller ID (hexadecimal)

Data 60 00 20 00 00 00 00 00

Motor current query: 40 00 21 01 00 00 00 00

Return ID: 0x0580000 + controller ID (hexadecimal)

Data 60 00 21 01 DATA 00 00 00

DATA =((unsigned char*)&send_float)

Fault query: 40 12 21 01 00 00 00 00

Return ID: 0x0580000 + controller ID (hexadecimal)

Data 60 12 21 01 DAT1 DAT2 00 00

DAT1 =((unsigned char*)&TYPE_RunData.err) [L]

DAT2 =((unsigned char*)&TYPE_RunData.err) [H]

TYPE_RunData.err is the fault code

Encoder speed query: 40 03 21 01 00 00 00 00

Return ID: 0x0580000 + controller ID (hexadecimal)

Data 60 03 21 01 DAT1 DAT2 00 00

DAT1 = ((unsigned char*)(&send_float))[L]

DAT2 = ((unsigned char*)(&send_float))[H]

Power supply voltage query: 40 0D 21 02 00 00 00 00

Return ID: 0x0580000 + controller ID (hexadecimal)

Data 60 0D 21 02 DATA 00 00 00

DATA = ((unsigned char*)(&send_float))

Radiator temperature query: 40 0F 21 01 00 00 00 00

Return ID: 0x0580000 + controller ID (hexadecimal)

Data 60 0F 21 01 DATA 00 00 00

DATA = ((unsigned char*)(&send_short))

Encoder count value query: 40 04 21 01 00 00 00 00

Return ID: 0x0580000 + controller ID (hexadecimal)

Data 60 04 21 01 DAT1 DAT2 DAT3 DAT4

DAT1 = ((unsigned char*)(&send_int))[4];

DAT2 = ((unsigned char*)(&send_int))[3];

DAT3 = ((unsigned char*)(&send_int))[2];

DAT4 = ((unsigned char*)(&send_int))[1];

AD input query: 40 05 21 01 00 00 00 00

Return ID: 0x0580000 + controller ID (hexadecimal)

Data 60 05 21 01 DAT1 DAT2 00 00

DAT1 = ((unsigned char*)(&send_float))[L]

DAT2 = ((unsigned char*)(&send_float))[H]

Program version query: 40 01 11 11 00 00 00 00

Return ID: 0x0580000 + controller ID (hexadecimal)

Data 60 01 11 11 DAT1 DAT2 DAT3 DAT4

DAT1 = ((unsigned char*)&send_int)[1];

DAT2 = ((unsigned char*)&send_int)[2];

DAT3 = ((unsigned char*)&send_int)[3];

DAT4 = ((unsigned char*)&send_int)[4];

Heartbeat return command:

Return ID: 0x0700000 + controller ID (hexadecimal)

Return instruction: **Data0 Data1 Data2 Data3 Data4 Data5 Data6 Data7**

Data0 Data1, Electrical Angle: 0—1000

Data2 Data3, motor speed: – speed — + speed

Data4 Data5, speed command: 0-1000 (rated speed) command value

Data6 Data7, Control_Close (fault code)

(Notice: the high data in the front and the low data is later)

4.3.3 CAN bus data description

4.3.3.1 Control mode

Data given ID 0x06000001	BX20	DataBox_MDL	DataBox_MDH	
		Write data address	DATA_L	DATA_H

DataBox_MDL=0x230**D**2001 Enable

DataBox_MDL=0x230**C**2001 Disable

DataBox_MDL=0x230**0**2001 Speed control

DataBox_MDL=0x230**1**2001 Torque control

DataBox_MDL=0x230**2**2001 Position control

Note: need to make up 8 digit, Eg: 23 0D 20 01 00 00 00 00

Speed: -1000 -- 1000, negative rated speed -- rated speed

Torque: -1000 -- 1000, negative rated torque x2 -- rated torque x2

Position: -25000 -- 25000, 2.5 circles clockwise -- 2.5 circles anticlockwise

4.3.3.2 Heartbeat data

	BX5	DataBox_MDL	DataBox_MDH	
Data feedback D 0x07000001	Electric angle	Motor rated speed	Given speed	Fault code

4.3.4 CAN bus control example

4.3.4.1 Speed Control:

(Speed command value %) * (The setted max speed in the software) = the real speed.
If the setting max speed is 80rpm, then the **Speed command set point -1000 - +1000 means -80rpm - +80rpm** (0xFC18) (0x03E8)

The software setting control mode is CAN control (0019 is set to 2)

The software setting control mode is set to speed control (0020 is set to 1)

The software sets the system address to 1 (0018 is set to 1)

- If you want set the speed +40 (rated speed 80)

Control command ID: 0x06000001 (extended ID)

Enable: 23 0d 20 01 00 00 00 00

Speed given: 23 00 20 01 01 F4 00 00 (0x01F4 = 500)

- If you want set the speed -40 (rated speed 80)

Control command ID: 0x06000001 (extended ID)

Enable: 23 0d 20 01 00 00 00 00

Speed given: 23 00 20 01 FE 0C FF FF

4.3.4.2 Position control:

Position given value -50000 - 50000 means 5 circles clockwise - 5 circles anticlockwise (0x3CB0 FFFF) (0XC350 0000)

The software setting control mode is CAN control (0019 is set to 2)

The software setting control mode is absolute position control (0020 is set to 3)

Or the software setting control mode is set to relative position control (0020 is set to 4)

The software sets the system address to 1 (0018 is set to 1)

Control command ID: 0x06000001 (extended ID)

- Data transmission order:

- (a) Disability 23 0C 20 01 00 00 00 00
- (b) Enable 23 0D 20 01 00 00 00 00
- (c) Position control: 23 02 20 01 DATA_L(h) DATA_L(l) DATA_H(h) DATA_H(l)

For example, you need the motor rotate 1.8 circles clockwise

- (a) Make sure the position control has been switched
- (b) Enable 23 0D 20 01 00 00 00 00
- (c) Position control command: 23 02 20 01 B9 B0 FF FF

For example, you need the motor to rotate the mechanical angle 76 degrees

counterclockwise ($76 * (10000 / 360) = 2052 = 0x0804$)

- (a) Make sure the position control has been switched
- (b) Enable 23 0D 20 01 00 00 00 00
- (c) Position control command: 23 02 20 01 08 04 00 00

4.4 Serial port instructions

4.4.1 General Configuration

Serial port configuration

The serial port communication port of the controller is set as follows:

- 115200bits/s
- 4-bit data
- 1 start bit
- Check code
- Hexadecimal

4.4.2 Send control command format

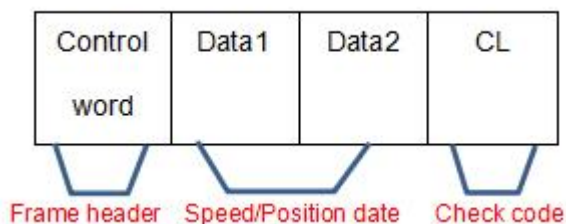

Frame Header: AD AC

AD: Enable, you can make the motor run.

AC: Disable, the motor/driver are in torqueless status.

Speed /Position Data:

[Data] is the given speed/position data, high before, low after.

The speed data range is -1000 ~ +1000, means - 80rpm ~ +80rpm (factory setting)

The position data range is -3000000~+3000000, means -300 circles ~ +300 circles (10000/circle)

Check code:

The check uses the sum check method, that is, starting from the frame head, accumulating all the bytes, and the low bit of the final result obtained is the check code.

Example: motor enable, speed 0rpm

AD 00 00 AD **Data feedback: AC xx xx xx**

Example: motor disable, speed 0rpm

AC 00 00 AC **Data feedback: AC xx xx xx**

Example: motor enable, speed 100rpm (Rated speed 100)

AD 03 E8 98 **Data feedback: AC xx xx xx**

Example: motor disable, the speed given 100rpm (Rated speed 100)

AC 03 E8 97 **Data feedback: AC xx xx xx**

Example: motor enable, the speed given -100rpm (Rated speed 100)

AD FC 18 C1 **Data feedback: AC xx xx xx**

Example: motor disable, the speed given -100rpm (Rated speed 100)

AD FC 18 54 Validation error **Data feedback: A8 xx xx xx**

- **Notice: Time interval between two instructions when sending instructions continuously.**
20ms < Time interval < 500ms

4.4.3 Return information format

- Every time the controller receives a control command, the controller will return a response data defined as follows: (hexadecimal)

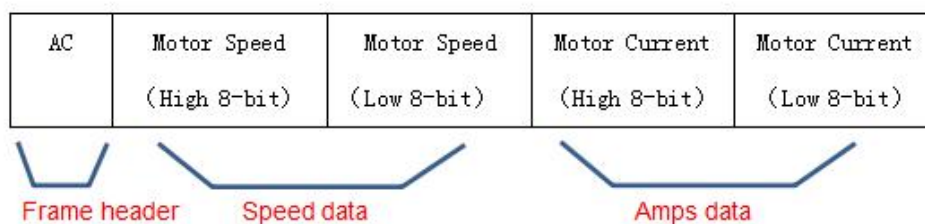

AC: Check passed.

A8: Check failed

4.4.4 Query data format

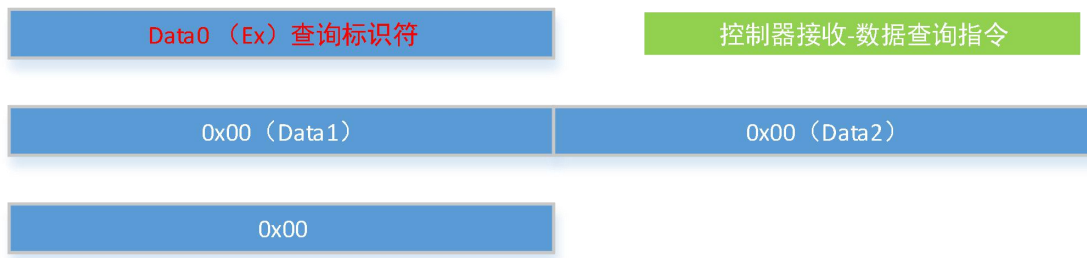

Marker (Data0): Ex means query data command.

Query data marker description:

- 0xE0 System control states
- 0xE1 Motor rotor position Electric angle (0-1000)
- 0xE2 Motor speed (rpm)
- 0xE3 Motor winding Amps (positive number)
- 0xE4 Motor rotor mechanical angle (0-10000)
- 0xE5 System controller voltage
- 0xE6 Motor/controller temperature
- 0xE7 Error code
- 0xE8 Motor rotor mechanical position (position mode)
- 0xEF System program version

Such as:

- Read motor speed (rpm)
The software send: E2 02 00 00 00
Controller feedback: E2 00 64 00 00
The motor speed is 100rpm

- Read controller current (A)
The software send: E2 02 00 00 00
Controller feedback: E2 00 64 00 00
The controller voltage is 10A

- Read controller voltage (V)
The software send: E5 00 00 00
Controller feedback: E5 00 0B 00 00

The controller voltage is 12V

- Read controller temperature (°C)

The software send: E6 00 00 00

Controller feedback: E6 1A 00 00 00

The controller temperature is 26°C

- Read motor position (10000/Circle)

The software send: E8 00 00 00

Controller feedback: ED 00 09 2D EE

The motor position is 601528

Note: The data returned by the query are all in hexadecimal and need to be converted to decimal to read.

- Read controller error code

The software send: E7 00 00 00

Controller feedback: E7 03 01 00 00

The controller error code is 03 01

Fault code failure resolution:

At first, convert the hexadecimal to binary, then check the “1” position from the right to the left, which corresponds to the indicator blinking frequency.

Eg: The feedback data is 03 01

0 3 0 1 (Hexadecimal)

0000 0011 0000 0001 (Binary); means faults 1, 9, 10.

check the "1" position from right to left.

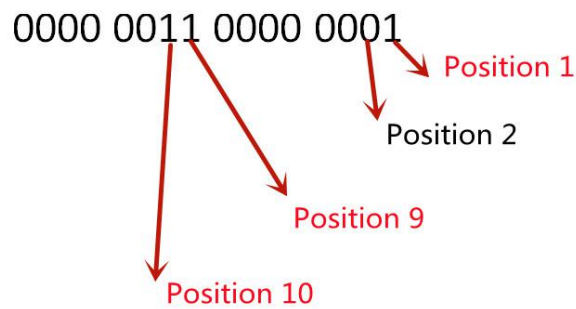

That means three faults : 1, 9, 10

Data	Definition	Cause of issue
1	Working normally	Disability state
2	Over voltage	Supply voltage is over 32V(adjustable)
3	Hardware overcurrent protection 60A	Overcurrent protection caused by motor short circuit and field tube damage
4	EEPROM error	Data saving error
5	Less voltage	Supply voltage is lower than 7V(adjustable)
6	brake	Turn on the brake signal
7	Software overcurrent protection (software set protection value)	The phase current reaches the software setting protection value for 1 second to stop output.
8	Control mode failure	Control mode selection error
9	Working mode failure	Speed, position working mode not selected or wrong
10	Speed loss protection	Actual speed exceeds 25% of rated value
11	Temperature alarm	The temperature above 85 °C
12	Hall error	Motor Hall is off or malfunctioning
13	Reserved	Reserved
14	232 break	232 mode, no 232 signal input
15	CAN break	CAN mode, no CAN signal input
16	Blocking for 2 seconds	Motor stalled 2s protection

V. Fault Protection and Reset

5.1 Fault protection basis

5.1.1 Temperature alarm

When the temperature of the drive exceeds 85 °C, a temperature alarm is generated; when it is restored to 80 °C, the alarm flag is cleared automatically.

5.1.2 Overcurrent protection

When the phase current reaches the setting value with setting time, it stops. Re-enable can reset the motor.

5.1.3 Overvoltage and undervoltage protection

The system will make undervoltage protection when the power supply voltage is lower than setting data.

And the system will make overvoltage protection when the power supply voltage is higher than setting data.

5.2 Fault information table

Protection category	Security Level	Turn off the PWM output	FAULT output
Temperature	Status latch	Yes	Yes
Overcurrent	Status latch	Yes	Yes
Undervoltage	Status latch	Yes	Yes
Overvoltage	Status latch	Yes	Yes
EEPROM error	Status latch	Yes	Yes

Note: When the fault status is locked, the controller will stop the power output; you can re-enable the motor to clear all fault flags.

Jinan Keya Electron Science And Technology Co.,Ltd

Email: sales@jnky.com

Contact: Nancy Ni

www.dcmotorkeya.com