

# XN16挖掘机

## CRAWLER EXCAVATOR

全国免费电话  
National toll-free **4000 990 778**

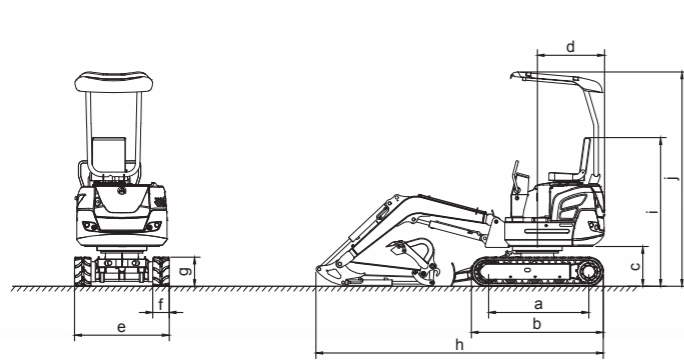

主要尺寸示意图  
Main dimensions schematic diagram

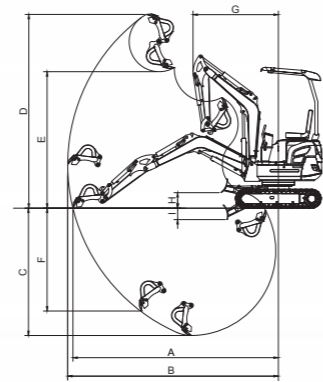

作业范围示意图  
Working range schematic diagram



进口洋马发动机  
Imported Yanmar engine

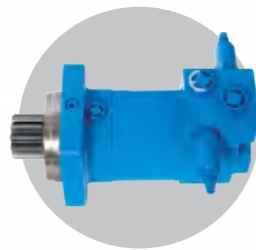

进口马达  
Imported motor



进口马达  
Imported motor



新型铸铁配重  
New Cast iron counter weight

技术性能参数 SPECIFICATION		单位 Unit	
整机重量 Machine Weight	kg	1400	
标准铲斗容量 Bucket capacity	m <sup>3</sup>	0.045	
工作装置形式 Working device form		反铲 Backhoe	
型号 Model		Yanmar 3TNV70 / 74F	
发动机 Engine	排量 Displacement	L	0.854
	额定输出功率/转速 Engine power/rpm	kw/r/min	10 / 11.2 / 2200
	最大扭矩 Max. torque	N.m/ r/min	51.9/1600
	最大行走速度 km/h	km/h	3
速度与挖掘力 Speed/Digging force	回转速度 Swing speed rpm	rpm	11
	最大爬坡能力 Max. Grade ability		30°
	铲斗挖掘力 Bucket digging force	kN	10.5
	斗杆挖掘力 Bucket arm digging force	kN	6.5
	最大牵引力 Maximum tractive force	kN	13.5
接地比压 Ground pressure	kPa	35	
履带材料 Track material		橡胶 Rubber	
液压及液体容量 Hydraulic and liquid capacity	泵型式 Pump type		齿轮泵 Gear pump
	工作压力 Pressure	MPa	16
	流量 Displacement	L/min	23.3
	液压油箱容量 Capacity of hydraulic tank	L	15.3
	发动机油容量最大(有效) Engine oil capacity	L	2.8 (1.3)
燃油箱容量 Fuel tank capacity	L	19	

主要尺寸 MAIN DIMENSION		单位 Unit	
a 轮距 Wheel base	mm	1130	
b 履带总长 Track length	mm	1450	
c 平台离地间隙 Upper chassis ground clearance	mm	437	
d 平台尾端回转半径 Counterweight turning radius	mm	740	
e 底盘宽度 Chassis width	mm	1110	
f 履带宽度 Track width	mm	230	
g 履带高度 Track height	mm	320	
h 运输长度 Transportation length	mm	3160	
i 座椅到地面高度 Height of seat to ground	mm	1637	
j 全车高度 Total height	mm	2377	

作业范围 OPERATING RANGE		单位 Unit	
A 最大挖掘半径(在地面) Max. digging radius on ground	mm	3470	
B 最大挖掘半径 Max. digging radius	mm	3560	
C 最大挖掘深度 Max. digging depth	mm	2150	
D 最大挖掘高度 Max. digging height	mm	3275	
E 最大卸载高度 Max. dumping height	mm	2310	
F 最大垂直挖深 Maximum vertical digging depth	mm	1740	
G 最小回转半径 Minimum turning radius	mm	1440	
H 推土铲最大提升高度 Maximum Lift Of Dozer blade	mm	262	
I 推土铲最大掘地深度 Maximum depth Of Dozer blade	mm	192	



- 日本原装进口动力
- 满足国三、欧五排放标准
- 节约30%油耗
- Japanese import engine
- EURO V / EPA Tier 4 emission
- Save 30% fuel consumption

小材 大用 犀牛 “智”造

### 山东肯石重工机械有限公司

SHANDONG KEN STONE HEAVY MACHINERY CO.,LTD



微信公众号



阿里巴巴店铺

地址：中国山东聊城西20公里（聊冠路） Address : 20 kilometers away from west of Liaocheng City, (Liaoguan Road), Shandong Province, China  
 热线电话：0086-15552147667 Hotline : 0086-15552147667  
 邮编：252512 Postal code : 252512  
 网址：www.sdxiiniu.com Website : www.sdxiiniu.com  
 邮箱：lucy@sdxiiniu.com E-mail : lucy@sdxiiniu.com

(产品配置参数如有变动，恕不另行通知) We reserve the right to improve or withdraw the specification or products without prior notice.

# XN16挖掘机

## CRAWLER EXCAVATOR

# XN18挖掘机

## CRAWLER EXCAVATOR

全国免费电话  
National toll-free **4000 990 778**

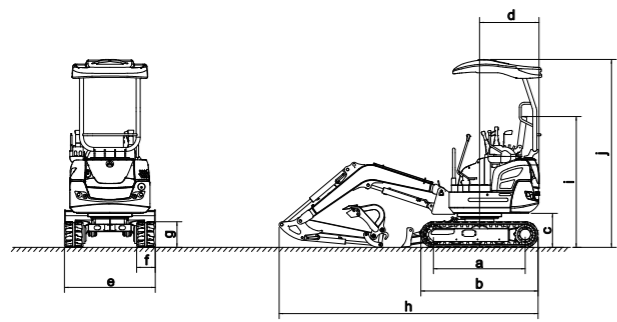

主要尺寸示意图  
Main dimensions schematic diagram

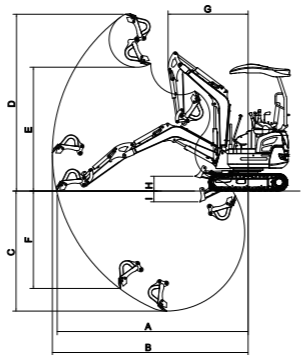

作业范围示意图  
Working range schematic diagram



进口洋马发动机  
Imported Yanmar engine

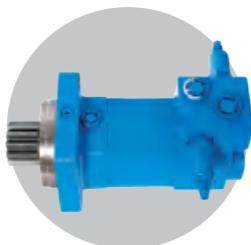

进口马达  
Imported motor



进口马达  
Imported motor



可选配钢履带  
Steel track for option

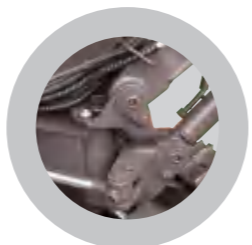

可选配动臂侧摆  
Swing boom for option

技术性能参数 SPECIFICATION		单位 Unit	
整机重量	Machine Weight	kg	1600
标准铲斗容量	Bucket capacity	m <sup>3</sup>	0.045
工作装置形式	Working device form	反铲 Backhoe	
发动机 Engine	型号 Model	Yanmar 3TNV70 / 74F	
	排量 Displacement	L	0.854
	额定输出功率/转速 Engine power/rpm	kw/r/min	10 / 11.2 / 2200
	最大扭矩 Max. torque	N.m/ r/min	51.9/1600
速度与挖掘力 Speed/Digging force	最大行走速度 km/h	km/h	3
	回转速度 Swing speed rpm	rpm	11
	最大爬坡能力 Max. Grade ability	30°	
	铲斗挖掘力 Bucket digging force kN	kN	10.5
斗杆挖掘力 Bucket arm digging force kN	kN		6.5
	最大牵引力 Maximum tractive force kN	kN	13.5
接地比压	Ground pressure kPa	kPa	40
履带材料	Track material	橡胶 rubber	
液压及液体容量 Hydraulic and liquid capacity	泵型式 Pump type	柱塞泵 Piston pump	
	工作压力 Pressure Mpa	Mpa	22
	流量 Displacement	L/min	39.6
	液压油箱容量 Hydraulic oil tank capacity	L	15.3
	发动机油容量最大(有效) Engine oil capacity	L	2.8 (1.3)
燃油箱容量	Fuel tank capacity	L	19

主要尺寸 MAIN DIMENSION		单位 Unit	
a 轮距	Wheel base	mm	1130
b 履带总长	Track length	mm	1450
c 平台离地间隙	Upper chassis ground clearance	mm	420
d 平台尾端回转半径	Counterweight turning radius	mm	730
e 底盘宽度	Chassis width	mm	1120
f 履带宽度	Track width	mm	230
g 履带高度	Track height	mm	320
h 运输长度	Transportation length	mm	3160
i 座椅到地面高度	Height of seat to ground	mm	1620
j 全车高度	Total height	mm	2377

作业范围 OPERATING RANGE		单位 Unit	
A 最大挖掘半径(在地面)	Max. digging radius on ground	mm	3500
B 最大挖掘半径	Max. digging radius	mm	3580
C 最大挖掘深度	Max. digging depth	mm	2190
D 最大挖掘高度	Max. digging height	mm	3230
E 最大卸载高度	Max. dumping height	mm	2260
F 最大垂直挖深	Maximum vertical digging depth	mm	1780
G 最小回转半径	Minimum turning radius	mm	1440
H 推土铲最大提升高度	Maximum Lift Of Dozer blade	mm	270
I 推土铲最大掘地深度	Maximum depth Of Dozer blade	mm	200



- 日本原装进口动力
- 满足国三、欧五排放标准
- 节约30%油耗
- Japanese import engine
- EURO V / EPA Tier 4 emission
- Save 30% fuel consumption

小材 大用 犀牛 “智” 造

### 山东肯石重工机械有限公司

SHANDONG KEN STONE HEAVY MACHINERY CO.,LTD



微信公众号



阿里巴巴店铺

地址：中国山东聊城西20公里（聊冠路） Address : 20 kilometers away from west of Liaocheng City, (Liaoguan Road), Shandong Province, China  
 热线电话：0086-15552147667 Hotline : 0086-15552147667  
 邮编：252512 Postal code : 252512  
 网址：www.sdxiiniu.com Website : www.sdxiiniu.com  
 邮箱：lucy@sdxiiniu.com E-mail : lucy@sdxiiniu.com

(产品配置参数如有变动，恕不另行通知) We reserve the right to improve or withdraw the specification or products without prior notice.

# XN18挖掘机

## CRAWLER EXCAVATOR