

# X9挖掘机

## WHEEL-CRAWLER EXCAVATOR

全国免费电话 National toll-free **4000 990 778**

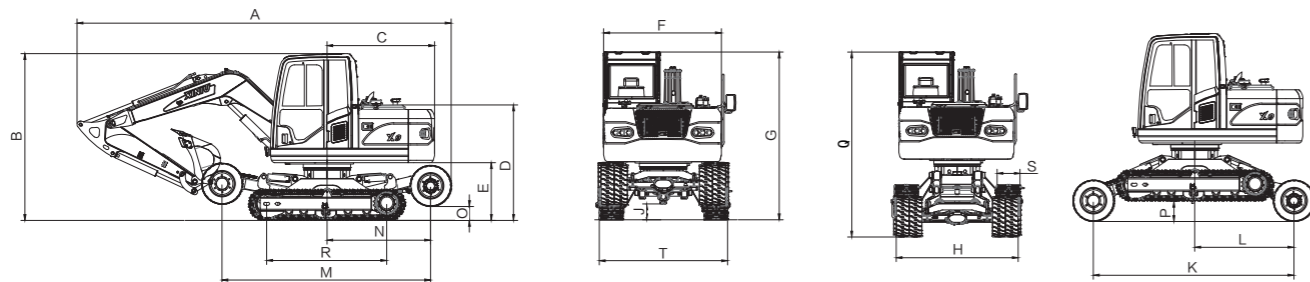

主要尺寸示意图  
Main dimensions schematic diagram

主要尺寸 MAIN DIMENSION	单位 Unit: mm	技术性能参数 SPECIFICATION	单位 Unit
A 总长度 Total length		整机重量 Machine Weight	8510 kg(挖) 8840kg(夹)
3.5m动臂+2.00m斗杆 Boom 3.5m+Bucket arm 2m	6570	标准铲斗容量 Bucket capacity	0.3 m <sup>3</sup>
B 总高度 Total height		发动机 Engine	
3.5m动臂+2.00m斗杆 Boom 3.5m+Bucket arm 2m	2982	型号 Model	Yanmar 4TNV98-ZCSLKC
C 后端回转半径 Counter weight turning radius	1836	排量 Displacement	3.319L
D 发动机罩高度 Engine hood height	2104	额定输出功率/转速 Engine power/rpm	46.3kW/2200 rpm
E 配重离地间隙 Counter weight ground clearance	1120	最大扭矩 Max. torque	223.3~243.5N.m/1600 ± 100 rpm
F 上部回转平台总宽度 Upper structure width	2000	选配发动机 Engine	
G 驾驶室高度 Cabin height (wheels up)	2982	型号 Model	Yanmar 4TNV98T-ZCSTYC
H 轮胎总宽度 Tire width	2120	排量 Displacement	3.319L
J 最小离地间隙 Minimum ground clearance	270	额定输出功率/转速 Rated power / speed	56.5kW /2200 rpm
K 升起后轮间距 Wheels up wheel gauge	3400	最大扭矩 Max. torque	273.3~298.2N.m/1650 ± 100rpm
L 升起后回转中心至后桥间距 Distance of swing center to rear wheel (wheels down)	1682	轮胎行走速度 Wheel travelling speed	21 km/h
M 降下后轮间距 Wheels down wheel gauge	3560	履带行走速度 Track travelling speed	3 km/h
N 降下后回转中心至后桥间距 Distance of swing center to rear wheel (wheels up)	1767	回转速度 Swing speed	9rpm
O 降下后轮胎离地间隙 Rear wheel ground clearance (wheels up)	300	最大爬坡能力 Max. grade ability	30°
P 升起后履带离地间隙 Tracks ground clearance (wheels down)	330	液压系统 Hydraulic system	力士乐负载敏感系统 Rexroth
Q 升起后总高 Total height (wheels down)	3190	泵型式 Pump	变量X1 variable capacity pump
R 履带轮距 Track wheel base	2050	设定压力 Pressure	25 MPa
S 履带宽度 Track width	400	流量 Displacement	132 L/min
T 左右履带总宽度 Track outer width	2160	液压油箱容量 Hydraulic oil tank capacity	175 L
		燃油箱容量 Fuel tank capacity	150 L
		发动机油容量最大(有效) Engine oil capacity	12 L

作业范围 OPERATING RANGE	单位 Unit: mm
工作装置 Working device	3.5m动臂+2m斗杆 Boom 3.5m+Arm 2m
A1 最大挖掘半径 Max. digging radius	6680
A 最大挖掘半径(在地面) Max. digging radius on ground	6555
B 最大挖掘深度 Max. digging depth	3572
C 最大切削高度 Max. Cutting height	6955
D 最大卸载高度 Max. dumping height	5245
E 最小回旋半径 Min. turning radius	2540
F 最大垂直挖深 Max. vertical digging depth	3255
铲斗挖掘力(KN) Bucket digging force	56
斗杆挖掘力(KN) Bucket arm digging force	36

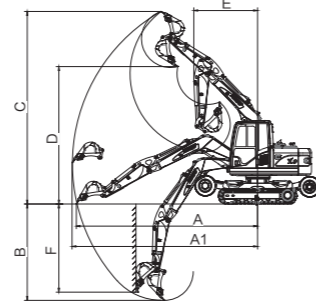

作业范围示意图  
Working range schematic diagram



- 获得国家发明专利
- 日本洋马动力
- 满足国三排放标准
- 节约30%油耗
- National invention patent product
- Japanese Yanmar engine
- Meet National III emission standard
- 30% fuel saving

### 山东肯石重工机械有限公司

SHANDONG KEN STONE HEAVY MACHINERY CO.,LTD



Wechat



Whatsapp

地址: 中国山东聊城西20公里(聊冠路) Address: 20 kilometers away from west of Liaocheng City, (Liaoguan Road), Shandong Province, China  
 热线电话: 0086 13406345925 Hotline: 0086-13406345925  
 邮编: 252512 Postal code: 252512  
 网址: www.sdxiiniu.com Website: www.sdxiiniu.com  
 邮箱: jan.excavator@gmail.com E-mail: jan.excavator@gmail.com  
 sales9@sdxiiniu.com sales9@sdxiiniu.com

(产品配置参数如有变动, 恕不另行通知) We reserve the right to improve or withdraw the specification or products without prior notice.

# X9挖掘机

## WHEEL-CRAWLER EXCAVATOR

# X9 挖掘机

## WHEEL-CRAWLER EXCAVATOR

**CE ISO TUV**  
Chinese Well-known Trademark

### 更强动力、更低油耗 Stronger power, lower fuel consumption

#### 日本洋马发动机

追求绿色排放与大功率输出的洋马TNV直喷柴油发动机。通过对燃油喷射系统的改良等，达到各国的尾气排放要求。且具有低噪音设计使作业有利于健康与环保。

#### Japanese Yanmar engine

Adopting strong power YANMAR TNV direct injection diesel engine, green emission, high power output. Through the improvement of fuel injection system, the exhaust emission standard can meet requirements of various countries. Low noise design makes operation beneficial to health and environmental protection.

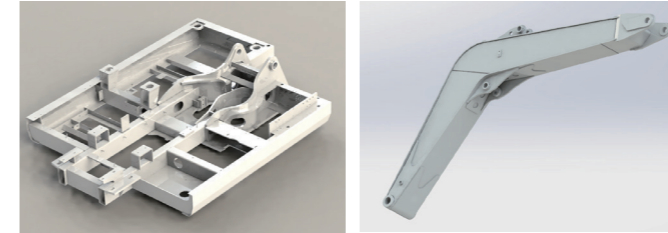
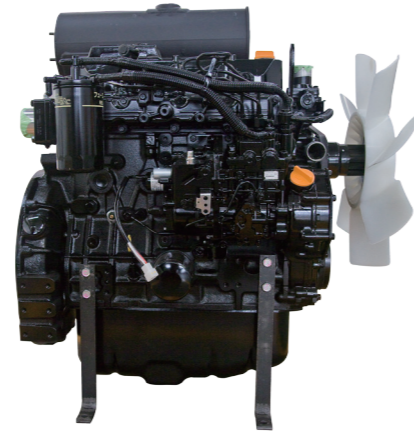

经有限元分析后优化的上转台及工作装置，结构更加合理，大大提高了转台及工作装置的强度及韧性。

After the finite element analysis, the structure of the upper turntable and the working device is more reasonable, which greatly improves the strength and toughness of the turntable and the working device.



并列式散热器，全网格式后门，通风量加大，大大提高了散热效率，后示灯全部藏进配重里面，避免了复杂工况中的碰撞。

Parataxis radiator, full steel mesh back door, increase ventilation, improving the cooling efficiency, the back lights hidden inside the counterweight completely, avoiding the collision at the complex conditions working.

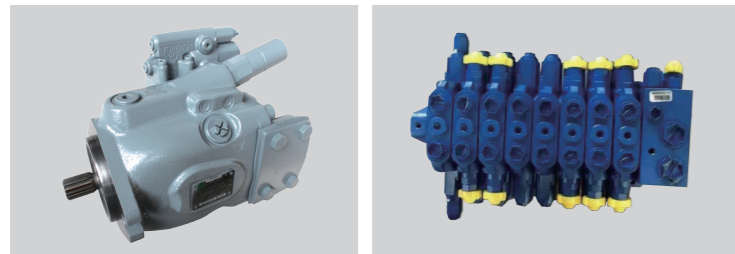

原装进口国际品牌柱塞泵、主阀，动作快，复合动作协调，可靠性高，使用寿命长。

Imported International brand plunger pump, main valve, quick moving, compound movement harmoniously, high reliability, long service time.

全新升级款驾驶室，外观漂亮，室内人体工程学设计，前置挂档机构，可调式悬浮座椅，冷暖空调，大屏幕液晶显示器，开阔的视野，操作更加舒适。

New upgraded cab, beautiful appearance, indoor ergonomic design, front gear shifting mechanism, adjustable suspension seat, air conditioning, large screen LCD, wide vision, more comfortable operation.



配备加固型前后驱动桥，变速箱及上下箱，承载能力更强。前后驱动桥带有轮边减速，其通过性更强，适合复杂路面，驱动力更强，适合爬坡。

The overall box-type structure chassis, with reinforced front and rear driven axles, reinforcement gearbox, reinforcement up and down box, more load carry capacity.

Front and rear driven axles with hub reduction, more passing ability, suitable for complex road, more driving power, suitable for climbing.

