

## The classic all-rounder – iglidur<sup>®</sup> G

Over 650 sizes available from stock

---

High wear resistance

---

Resistance to dust and dirt

---

Cost-effective

---

Lubrication and maintenance-free

---



## Excellent price-performance ratio

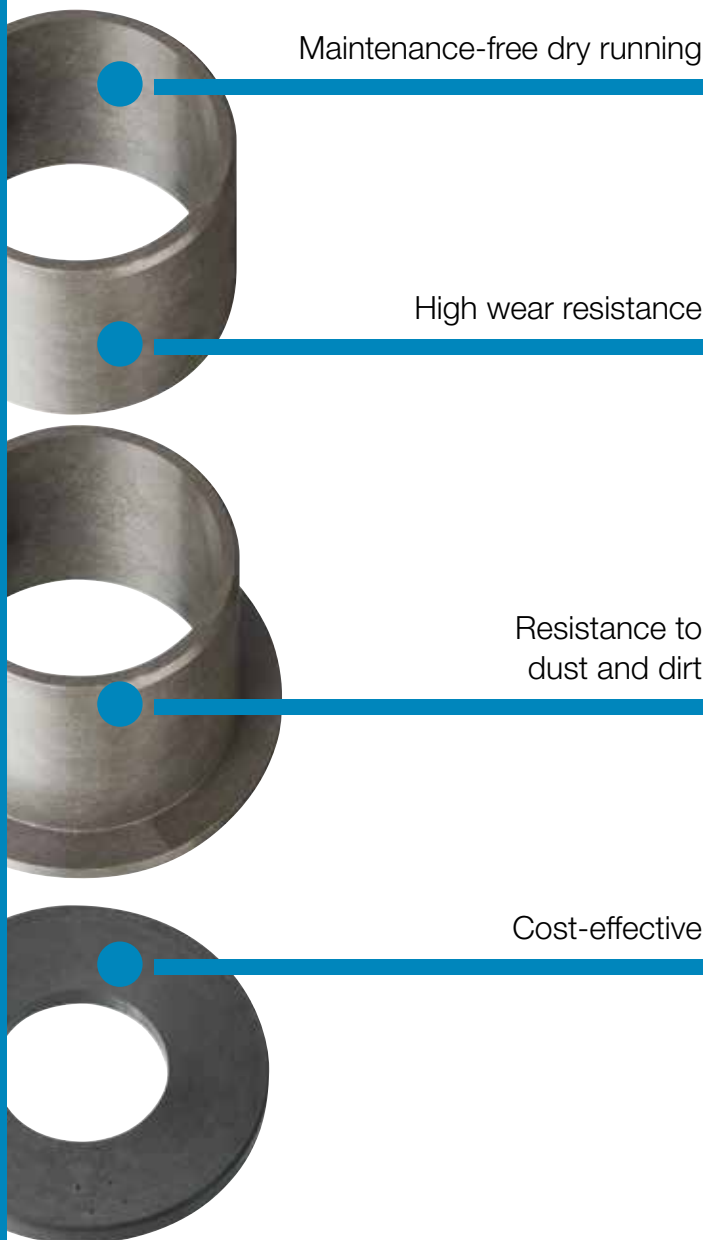

Maintenance-free dry running

High wear resistance

Resistance to dust and dirt

Cost-effective

iglidur® G bearings cover an extremely wide range of different requirements – they are truly "all-round". The material is ideal for universal applications, a truly "all-round". Typical applications include medium to high loads, medium sliding speeds and medium temperatures.



### When to use it?

- Economical all-round performance bearing
- For low to average surface speeds
- When the bearing needs to run on different shaft materials
- For oscillating and rotational movements



### When not to use it?

- When mechanical reaming of the wall surface is necessary
  - ▶ iglidur® M250, page 95
- When the highest wear resistance is required
  - ▶ iglidur® W300, page 153
- When universal chemical resistance is required
  - ▶ iglidur® X, page 245
- When temperatures are constantly higher than +130 °C
  - ▶ iglidur® H, page 313
  - ▶ iglidur® X, page 245
  - ▶ iglidur® H370, page 305
- For underwater use
  - ▶ iglidur® H370, page 305

### Typical application areas

- Agricultural machines
- Construction machinery industry
- Machine building
- Sports and leisure
- Automotive industry
- Mechatronics



#### Available from stock

Detailed information about delivery time online.



#### Block pricing online

No minimum order value. From batch size 1.



Max. +130 °C

Min. -40 °C



Ø 1.5–195 mm

More dimensions upon request



#### Imperial dimensions available

▶ From page 1391



#### Online product finder

▶ [www.igus.eu/iglidur-finder](http://www.igus.eu/iglidur-finder)

## Material properties

| General properties                                      | Unit                               | iglidur® G         | Testing method |
|---|------------------------------------|--------------------|----------------|
| Density   | g/cm <sup>3</sup>                  | 1.46               |                |
| Colour  |                                    | dark grey          |                |
| Max. moisture absorption at +23 °C/50 % r.h.            | % weight                           | 0.7                | DIN 53495      |
| Max. water absorption                                   | % weight                           | 4.0                |                |
| Coefficient of sliding friction, dynamic, against steel | μ                                  | 0.08–0.15          |                |
| pv value, max. (dry)                                    | MPa · m/s                          | 0.42               |                |
| Mechanical properties                                   |                                    |                    |                |
| Flexural modulus  | MPa                                | 7,800              | DIN 53457      |
| Flexural strength at +20 °C                             | MPa                                | 210                | DIN 53452      |
| Compressive strength                                    | MPa                                | 78                 |                |
| Max. recommended surface pressure (+20 °C)              | MPa                                | 80                 |                |
| Shore-D hardness  |                                    | 81                 | DIN 53505      |
| Physical and thermal properties                         |                                    |                    |                |
| Max. long-term application temperature                  | °C                                 | +130               |                |
| Max. short-term application temperature                 | °C                                 | +220               |                |
| Min. long-term application temperature                  | °C                                 | -40                |                |
| Heat conductivity                                       | W/m · K                            | 0.24               | ASTM C 177     |
| Coefficient of thermal expansion (at +23 °C)            | K <sup>-1</sup> · 10 <sup>-5</sup> | 9                  | DIN 53752      |
| Electrical properties                                   |                                    |                    |                |
| Specific contact resistance                             | Ωcm                                | > 10 <sup>13</sup> | DIN IEC 93     |
| Surface resistance                                      | Ω                                  | > 10 <sup>11</sup> | DIN 53482      |

Table 01: Material properties table

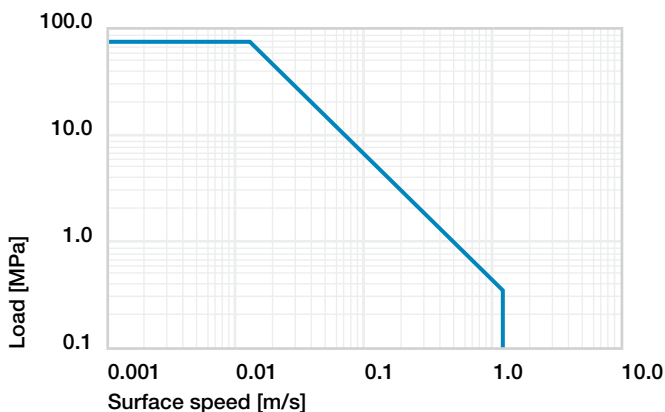

Diagram 01: Permissible pv values for iglidur® G bearings with a wall thickness of 1 mm dry running against a steel shaft, at +20 °C, mounted in a steel housing

### Moisture absorption

The moisture absorption of iglidur® G plain bearings is approximately 0.7 % weight in standard climatic conditions. The saturation limit submerged in water is 4 % weight. This must be taken into account for these types of applications.

► Diagram, [www.igus.eu/g-moisture](http://www.igus.eu/g-moisture)

### Vacuum

iglidur® G plain bearings outgas in a vacuum. Use in vacuum is only possible with dehumidified bearings.

### Radiation resistance

Plain bearings made from iglidur® G are resistant to radiation up to an intensity of  $3 \cdot 10^2$  Gy.

### UV resistance

iglidur® G plain bearings are permanently resistant to UV radiation.

| Medium                          | Resistance |
|---------------------------------|------------|
| Alcohol                         | + to 0     |
| Hydrocarbons                    | +          |
| Greases, oils without additives | +          |
| Fuels                           | +          |
| Diluted acids                   | 0 to -     |
| Strong acids                    | -          |
| Diluted alkalines               | +          |
| Strong alkalines                | 0          |

+ resistant 0 conditionally resistant - not resistant

All data given at room temperature [+20 °C]

Table 02: Chemical resistance

► Chemical table, page 1478

iglidur® G is the decathlete among iglidur® materials. It performs exceedingly well in all technical disciplines and is the classic all-rounder, primarily with respect to the overall general, mechanical, thermal and tribological specifications.

## Mechanical properties

With increasing temperatures, the compressive strength of iglidur® G plain bearings decreases. The diagram 02 shows this inverse relationship. However, at the long-term maximum temperature of +130 °C the permissible surface pressure is almost 35 MPa. The permissible maximum surface pressure is a mechanical material parameter. No conclusions regarding the tribological properties can be drawn from this.

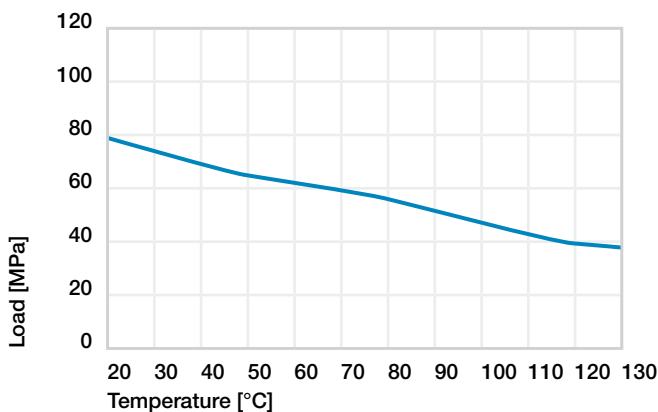

Diagram 02: Permissible maximum surface pressure of as a function of temperature (80 MPa at +20 °C)

Diagram 03 shows the elastic deformation of iglidur® G at radial loads. The plastic deformation is minimal up to a pressure of approximately 100 MPa. However, it is also dependent on the service time.

► Surface pressure, page 41

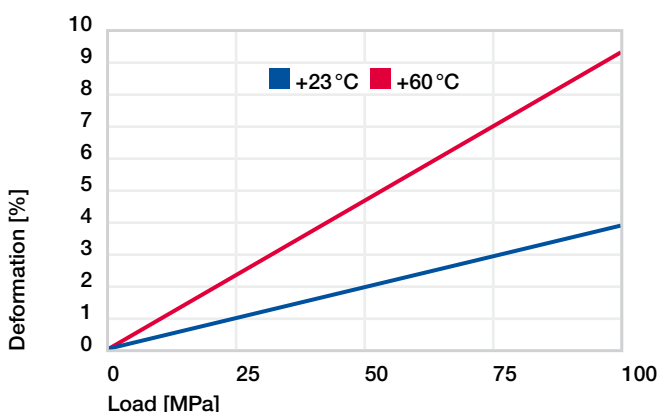

Diagram 03: Deformation under pressure and temperature

## Permissible surface speeds

iglidur® G has been developed for low to medium surface speeds. The maximum values shown in table 03 can only be achieved at low pressures. At the given speeds, friction can cause a temperature increase to maximum permissible levels. In practice, though, this temperature level is rarely reached due to varying application conditions.

► Surface speed, page 44

| m/s        | Rotating | Oscillating | Linear |
|------------|----------|-------------|--------|
| Continuous | 1        | 0.7         | 4      |
| Short-term | 2        | 1.4         | 5      |

Table 03: Maximum surface speeds

## Temperatures

The ambient temperatures greatly influence the wear performance of plastic bearings. The temperatures prevailing in the bearing system also have an influence on the bearing wear. With increasing temperatures, the wear increases and this effect is significant when temperatures rise over +120 °C. At temperatures over +80 °C an additional securing is required.

► Application temperatures, page 49

► Additional securing, page 49

## Friction and wear

Similar to wear resistance, the coefficient of friction  $\mu$  also changes with the speed and load (diagrams 04 and 05).

► Coefficients of friction and surfaces, page 47

► Wear resistance, page 50

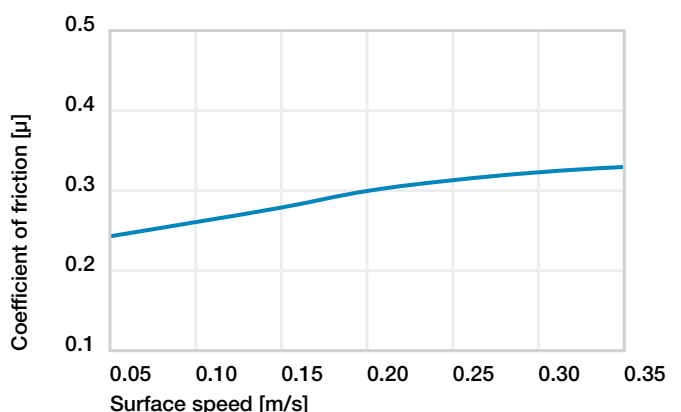

Diagram 04: Coefficient of friction as a function of the surface speed, p = 0.75 MPa

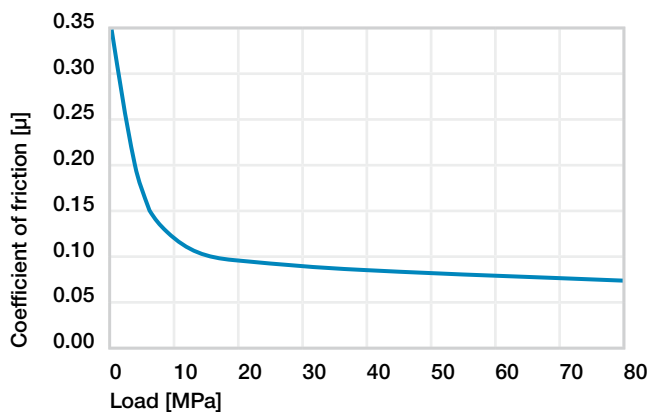

Diagram 05: Coefficient of friction as a function of the pressure,  $v = 0.01$  m/s

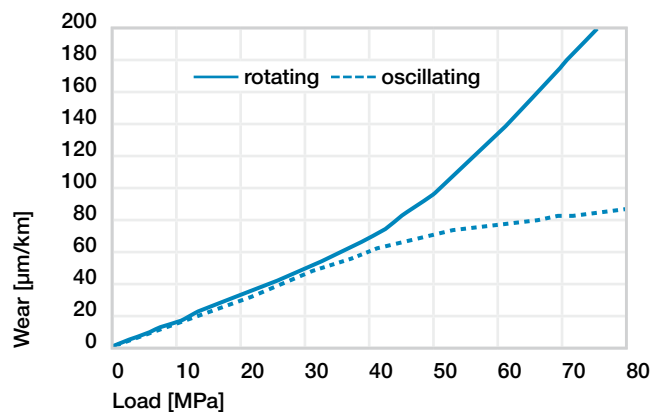

Diagram 07: Wear for oscillating and rotating applications with shaft material Cf53 hardened and ground steel, as a function of the pressure

### Shaft materials

Friction and wear are to a large extent also highly dependent on the shaft materials. Shafts that are too smooth, increase both the coefficient of friction and the wear of the bearing. For iglidur® G a ground surface with an average roughness  $R_a = 0.8 \mu\text{m}$  is recommended. Diagram 06 shows results of testing different shaft materials with plain bearings made from iglidur® G. It is important to notice that with increasing loads, the recommended hardness of the shaft increases. The "soft" shafts tend to wear more easily and thus the wear of the overall system. If the loads exceed 2 MPa it is important to recognise that the wear rate (the gradient of the curves) clearly decreases with the hard shaft materials. If the shaft material you plan on using is not shown in these test results, please contact us.

► Shaft materials, page 52

| iglidur® G   | Dry       | Greases | Oil  | Water |
|--------------|-----------|---------|------|-------|
| C.o.f. $\mu$ | 0.08–0.15 | 0.09    | 0.04 | 0.04  |

Table 04: Coefficient of friction against steel ( $R_a = 1 \mu\text{m}$ , 50 HRC)

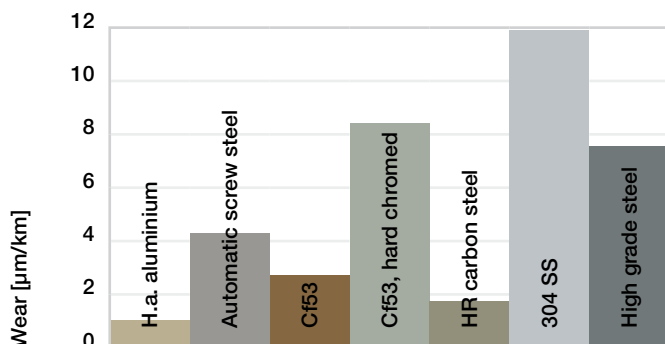

Diagram 06: Wear, rotating with different shaft materials,  $p = 1$  MPa,  $v = 0.3$  m/s

### Installation tolerances

iglidur® G plain bearings are standard bearings for shafts with h-tolerance (recommended minimum h9). The bearings are designed for pressfit into a housing machined to a H7 tolerance. After being assembled into a nominal size housing, the inner diameter automatically adjusts to the E10 tolerances. For particular dimensions the tolerance differs depending on the wall thickness (please see product range table).

► Testing methods, page 57

| Diameter d1 [mm] | Shaft h9 [mm] | iglidur® G E10 [mm] | Housing H7 [mm] |
|------------------|---------------|---------------------|-----------------|
| up to 3          | 0–0.025       | +0.014 +0.054       | 0 +0.010        |
| > 3 to 6         | 0–0.030       | +0.020 +0.068       | 0 +0.012        |
| > 6 to 10        | 0–0.036       | +0.025 +0.083       | 0 +0.015        |
| > 10 to 18       | 0–0.043       | +0.032 +0.102       | 0 +0.018        |
| > 18 to 30       | 0–0.052       | +0.040 +0.124       | 0 +0.021        |
| > 30 to 50       | 0–0.062       | +0.050 +0.150       | 0 +0.025        |
| > 50 to 80       | 0–0.074       | +0.060 +0.180       | 0 +0.030        |
| > 80 to 120      | 0–0.087       | +0.072 +0.212       | 0 +0.035        |
| >120 to 180      | 0–0.100       | +0.085 +0.245       | 0 +0.040        |

Table 05: Important tolerances for plain bearings according to ISO 3547-1 after pressfit

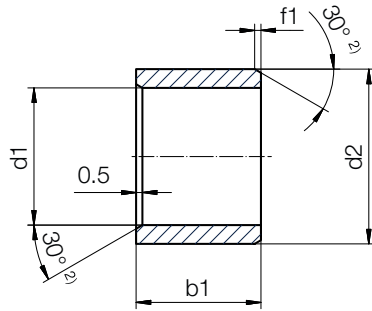

### Order key

Type      Dimensions [mm]

**G S M - 0103-02**

|                   |        |        |            |            |           |
|-------------------|--------|--------|------------|------------|-----------|
| iglidur® material | Form S | Metric | Inner-Ø d1 | Outer-Ø d2 | Length b1 |
|-------------------|--------|--------|------------|------------|-----------|

<sup>2)</sup> Thickness < 1 mm: chamfer = 20°

Chamfer in relation to the d1

|          |       |        |         |        |
|----------|-------|--------|---------|--------|
| d1 [mm]: | Ø 1-6 | Ø 6-12 | Ø 12-30 | Ø > 30 |
| f [mm]:  | 0.3   | 0.5    | 0.8     | 1.2    |

### Dimensions [mm]

| d1  | d1-<br>Tolerance <sup>3)</sup> | d2  | b1<br>h13 | Part No.             |
|-----|--------------------------------|-----|-----------|----------------------|
| 1.5 |                                | 3.0 | 2.0       | <b>GSM-0103-02</b>   |
| 2.0 |                                | 3.5 | 3.0       | <b>GSM-0203-03</b>   |
| 2.5 | +0.014                         | 4.5 | 5.0       | <b>GSM-02504-05</b>  |
| 3.0 | +0.054                         | 4.5 | 3.0       | <b>GSM-0304-03</b>   |
| 3.0 |                                | 4.5 | 5.0       | <b>GSM-0304-05</b>   |
| 3.0 |                                | 4.5 | 6.0       | <b>GSM-0304-06</b>   |
| 4.0 |                                | 5.5 | 4.0       | <b>GSM-0405-04</b>   |
| 4.0 | +0.020                         | 5.5 | 6.0       | <b>GSM-0405-06</b>   |
| 4.5 | +0.068                         | 6.0 | 8.0       | <b>GSM-0406-08</b>   |
| 4.0 |                                | 7.0 | 5.5       | <b>GSM-0407-05</b>   |
| 5.0 |                                | 6.0 | 4.6       | <b>GSM-0506-046</b>  |
| 5.0 | +0.010                         | 6.0 | 5.0       | <b>GSM-0506-05</b>   |
| 5.0 | +0.040                         | 6.0 | 7.0       | <b>GSM-0506-07</b>   |
| 5.0 |                                | 7.0 | 5.0       | <b>GSM-0507-05</b>   |
| 5.0 | +0.020                         | 7.0 | 7.0       | <b>GSM-0507-07</b>   |
| 5.0 | +0.068                         | 7.0 | 8.0       | <b>GSM-0507-08</b>   |
| 5.0 |                                | 7.0 | 10.0      | <b>GSM-0507-10</b>   |
| 6.0 |                                | 7.0 | 6.0       | <b>GSM-0607-06</b>   |
| 6.0 |                                | 7.0 | 12.0      | <b>GSM-0607-12</b>   |
| 6.0 | +0.010                         | 7.0 | 17.0      | <b>GSM-0607-17</b>   |
| 6.0 | +0.040                         | 7.0 | 17.5      | <b>GSM-0607-17.5</b> |
| 6.0 |                                | 7.0 | 19.0      | <b>GSM-0607-19</b>   |
| 6.0 |                                | 8.0 | 1.5       | <b>GSM-0608-015</b>  |
| 6.0 |                                | 8.0 | 2.5       | <b>GSM-0608-025</b>  |
| 6.0 | +0.020                         | 8.0 | 3.0       | <b>GSM-0608-03</b>   |
| 6.0 | +0.068                         | 8.0 | 4.0       | <b>GSM-0608-04</b>   |
| 6.0 |                                | 8.0 | 5.0       | <b>GSM-0608-05</b>   |
| 6.0 |                                | 8.0 | 5.5       | <b>GSM-0608-055</b>  |

**i** Dimensions according to ISO 3547-1 and special dimensions

**inch** Imperial dimensions available  
▶ From page 1402

| d1  | d1-<br>Tolerance <sup>3)</sup> | d2   | b1<br>h13 | Part No.           |
|-----|--------------------------------|------|-----------|--------------------|
| 6.0 |                                | 8.0  | 6.0       | <b>GSM-0608-06</b> |
| 6.0 |                                | 8.0  | 8.0       | <b>GSM-0608-08</b> |
| 6.0 | +0.020                         | 8.0  | 9.5       | <b>GSM-0608-09</b> |
| 6.0 | +0.068                         | 8.0  | 10.0      | <b>GSM-0608-10</b> |
| 6.0 |                                | 8.0  | 11.8      | <b>GSM-0608-11</b> |
| 6.0 |                                | 8.0  | 13.8      | <b>GSM-0608-13</b> |
| 7.0 | +0.013                         | 8.0  | 10.0      | <b>GSM-0708-10</b> |
| 7.0 | +0.049                         | 8.0  | 19.0      | <b>GSM-0708-19</b> |
| 7.0 |                                | 9.0  | 8.0       | <b>GSM-0709-08</b> |
| 7.0 | +0.025                         | 9.0  | 9.0       | <b>GSM-0709-09</b> |
| 7.0 | +0.083                         | 9.0  | 10.0      | <b>GSM-0709-10</b> |
| 7.0 |                                | 9.0  | 12.0      | <b>GSM-0709-12</b> |
| 8.0 |                                | 9.0  | 5.0       | <b>GSM-0809-05</b> |
| 8.0 | +0.013                         | 9.0  | 6.0       | <b>GSM-0809-06</b> |
| 8.0 | +0.049                         | 9.0  | 8.0       | <b>GSM-0809-08</b> |
| 8.0 |                                | 9.0  | 12.0      | <b>GSM-0809-12</b> |
| 8.0 |                                | 10.0 | 5.0       | <b>GSM-0810-05</b> |
| 8.0 |                                | 10.0 | 6.0       | <b>GSM-0810-06</b> |
| 8.0 |                                | 10.0 | 6.8       | <b>GSM-0810-07</b> |
| 8.0 |                                | 10.0 | 8.0       | <b>GSM-0810-08</b> |
| 8.0 |                                | 10.0 | 10.0      | <b>GSM-0810-10</b> |
| 8.0 | +0.025                         | 10.0 | 12.0      | <b>GSM-0810-12</b> |
| 8.0 | +0.083                         | 10.0 | 13.8      | <b>GSM-0810-13</b> |
| 8.0 |                                | 10.0 | 14.0      | <b>GSM-0810-14</b> |
| 8.0 |                                | 10.0 | 15.0      | <b>GSM-0810-15</b> |
| 8.0 |                                | 10.0 | 16.0      | <b>GSM-0810-16</b> |
| 8.0 |                                | 10.0 | 18.0      | <b>GSM-0810-18</b> |
| 8.0 |                                | 10.0 | 20.0      | <b>GSM-0810-20</b> |

<sup>3)</sup> After press-fit. Testing methods ▶ Page 57

## Sleeve bearing (Form S)

### Dimensions [mm]

| d1   | d1-<br>Tolerance <sup>3)</sup> | d2   | b1<br>h13 | Part No.            | d1     | d1-<br>Tolerance <sup>3)</sup> | d2   | b1<br>h13          | Part No.             |
|------|--------------------------------|------|-----------|---------------------|--------|--------------------------------|------|--------------------|----------------------|
| 8.0  | +0.025                         | 10.0 | 22.0      | <b>GSM-0810-22</b>  | 12.0   |                                | 14.0 | 25.0               | <b>GSM-1214-25</b>   |
| 8.0  | +0.083                         | 10.1 | 25.0      | <b>GSM-0810-25</b>  | 12.0   | +0.032                         | 15.0 | 6.0                | <b>GSM-1215-06</b>   |
| 8.0  | +0.040                         | 12.0 | 9.0       | <b>GSM-0812-09</b>  | 12.0   | +0.102                         | 15.0 | 22.0               | <b>GSM-1215-22</b>   |
|      | 12.0                           |      |           |                     | +0.050 | 16.0                           | 10.0 | <b>GSM-1216-10</b> |                      |
| 9.0  | +0.013                         | 10.0 | 12.0      | <b>GSM-0910-12</b>  | 12.0   | +0.160                         | 16.0 | 20.0               | <b>GSM-1216-20</b>   |
| 9.0  | +0.049                         | 10.0 | 16.0      | <b>GSM-0910-16</b>  | 13.0   |                                | 15.0 | 7.0                | <b>GSM-1315-070</b>  |
| 9.0  | +0.025                         | 11.0 | 6.0       | <b>GSM-0911-06</b>  | 13.0   |                                | 15.0 | 7.5                | <b>GSM-1315-075</b>  |
| 9.0  | +0.083                         | 11.0 | 20.0      | <b>GSM-0911-20</b>  | 13.0   |                                | 15.0 | 10.0               | <b>GSM-1315-10</b>   |
| 10.0 |                                | 11.0 | 6.0       | <b>GSM-1011-06</b>  | 13.0   |                                | 15.0 | 15.0               | <b>GSM-1315-15</b>   |
| 10.0 |                                | 11.0 | 7.0       | <b>GSM-1011-07</b>  | 13.0   |                                | 15.0 | 20.0               | <b>GSM-1315-20</b>   |
| 10.0 | +0.013                         | 11.0 | 10.0      | <b>GSM-1011-10</b>  | 13.0   |                                | 15.0 | 25.0               | <b>GSM-1315-25</b>   |
| 10.0 | +0.049                         | 11.0 | 20.0      | <b>GSM-1011-20</b>  | 14.0   | +0.032                         | 16.0 | 3.0                | <b>GSM-1416-03</b>   |
| 10.0 |                                | 11.0 | 25.0      | <b>GSM-1011-25</b>  | 14.0   | +0.102                         | 16.0 | 6.0                | <b>GSM-1416-06</b>   |
| 10.0 |                                | 11.0 | 30.0      | <b>GSM-1011-30</b>  | 14.0   |                                | 16.0 | 8.0                | <b>GSM-1416-08</b>   |
| 10.0 |                                | 12.0 | 4.0       | <b>GSM-1012-04</b>  | 14.0   |                                | 16.0 | 10.0               | <b>GSM-1416-10</b>   |
| 10.0 |                                | 12.0 | 4.5       | <b>GSM-1012-045</b> | 14.0   |                                | 16.0 | 12.0               | <b>GSM-1416-12</b>   |
| 10.0 |                                | 12.0 | 5.0       | <b>GSM-1012-05</b>  | 14.0   |                                | 16.0 | 15.0               | <b>GSM-1416-15</b>   |
| 10.0 |                                | 12.0 | 6.0       | <b>GSM-1012-06</b>  | 14.0   |                                | 16.0 | 20.0               | <b>GSM-1416-20</b>   |
| 10.0 |                                | 12.0 | 7.0       | <b>GSM-1012-07</b>  | 14.0   |                                | 16.0 | 25.0               | <b>GSM-1416-25</b>   |
| 10.0 |                                | 12.0 | 8.0       | <b>GSM-1012-08</b>  | 14.0   |                                | 16.0 | 45.0               | <b>GSM-1416-45</b>   |
| 10.0 | +0.025                         | 12.0 | 9.0       | <b>GSM-1012-09</b>  | 15.0   | +0.016                         | 16.0 | 10.0               | <b>GSM-1516-10</b>   |
| 10.0 | +0.083                         | 12.0 | 10.0      | <b>GSM-1012-10</b>  | 15.0   | +0.059                         | 16.0 | 15.0               | <b>GSM-1516-15</b>   |
| 10.0 |                                | 12.0 | 12.0      | <b>GSM-1012-12</b>  | 15.0   |                                | 17.0 | 4.0                | <b>GSM-1517-04</b>   |
| 10.0 |                                | 12.0 | 14.0      | <b>GSM-1012-14</b>  | 15.0   |                                | 17.0 | 10.0               | <b>GSM-1517-10</b>   |
| 10.0 |                                | 12.0 | 15.0      | <b>GSM-1012-15</b>  | 15.0   |                                | 17.0 | 12.0               | <b>GSM-1517-12</b>   |
| 10.0 |                                | 12.0 | 17.0      | <b>GSM-1012-17</b>  | 15.0   |                                | 17.0 | 15.0               | <b>GSM-1517-15</b>   |
| 10.0 |                                | 12.0 | 20.0      | <b>GSM-1012-20</b>  | 15.0   |                                | 17.0 | 20.0               | <b>GSM-1517-20</b>   |
| 10.0 |                                | 13.0 | 13.5      | <b>GSM-1013-13</b>  | 15.0   |                                | 17.0 | 25.0               | <b>GSM-1517-25</b>   |
| 10.0 | +0.025                         | 14.0 | 10.0      | <b>GSM-1014-10</b>  | 16.0   |                                | 18.0 | 5.5                | <b>GSM-1618-055</b>  |
| 10.0 | +0.115                         | 14.0 | 20.0      | <b>GSM-1014-20</b>  | 16.0   |                                | 18.0 | 8.0                | <b>GSM-1618-08</b>   |
| 10.0 | +0.040                         | 16.0 | 10.0      | <b>GSM-1016-10</b>  | 16.0   | +0.032                         | 18.0 | 10.0               | <b>GSM-1618-10</b>   |
|      | +0.130                         |      |           |                     | 16.0   | +0.102                         | 18.0 | 12.0               | <b>GSM-1618-12</b>   |
| 12.0 |                                | 13.0 | 4.7       | <b>GSM-1213-047</b> | 16.0   |                                | 18.0 | 13.5               | <b>GSM-1618-13.5</b> |
| 12.0 | +0.016                         | 13.0 | 10.0      | <b>GSM-1213-10</b>  | 16.0   |                                | 18.0 | 15.0               | <b>GSM-1618-15</b>   |
| 12.0 | +0.059                         | 13.0 | 12.0      | <b>GSM-1213-12</b>  | 16.0   |                                | 18.0 | 20.0               | <b>GSM-1618-20</b>   |
| 12.0 |                                | 13.0 | 15.0      | <b>GSM-1213-15</b>  | 16.0   |                                | 18.0 | 25.0               | <b>GSM-1618-25</b>   |
| 12.0 |                                | 14.0 | 4.0       | <b>GSM-1214-04</b>  | 16.0   |                                | 18.0 | 30.0               | <b>GSM-1618-30</b>   |
| 12.0 |                                | 14.0 | 5.0       | <b>GSM-1214-05</b>  | 16.0   |                                | 18.0 | 38.5               | <b>GSM-1618-38.5</b> |
| 12.0 |                                | 14.0 | 6.0       | <b>GSM-1214-06</b>  | 16.0   |                                | 18.0 | 50.0               | <b>GSM-1618-50</b>   |
| 12.0 |                                | 14.0 | 8.0       | <b>GSM-1214-08</b>  | 17.0   |                                | 19.0 | 15.0               | <b>GSM-1719-15</b>   |
| 12.0 | +0.032                         | 14.0 | 10.0      | <b>GSM-1214-10</b>  | 18.0   | +0.016                         | 19.0 | 15.0               | <b>GSM-1819-15</b>   |
| 12.0 | +0.102                         | 14.0 | 12.0      | <b>GSM-1214-12</b>  |        |                                |      |                    |                      |
| 12.0 |                                | 14.0 | 14.0      | <b>GSM-1214-14</b>  | 18.0   | +0.032                         | 20.0 | 6.0                | <b>GSM-1820-06</b>   |
| 12.0 |                                | 14.0 | 15.0      | <b>GSM-1214-15</b>  | 18.0   | +0.102                         | 20.0 | 10.0               | <b>GSM-1820-10</b>   |
| 12.0 |                                | 14.0 | 20.0      | <b>GSM-1214-20</b>  | 18.0   |                                | 20.0 | 12.0               | <b>GSM-1820-12</b>   |

<sup>3)</sup> After press-fit. Testing methods ► Page 57



## Sleeve bearing (Form S)

## Dimensions [mm]

| d1   | d1-<br>Tolerance <sup>3)</sup> | d2   | b1<br>h13 | Part No.             | d1   | d1-<br>Tolerance <sup>3)</sup> | d2   | b1<br>h13 | Part No.            |
|------|--------------------------------|------|-----------|----------------------|------|--------------------------------|------|-----------|---------------------|
| 18.0 |                                | 20.0 | 15.0      | <b>GSM-1820-15</b>   | 24.0 |                                | 27.0 | 20.0      | <b>GSM-2427-20</b>  |
| 18.0 |                                | 20.0 | 20.0      | <b>GSM-1820-20</b>   | 24.0 | +0.040                         | 27.0 | 24.0      | <b>GSM-2427-24</b>  |
| 18.0 | +0.032                         | 20.0 | 25.0      | <b>GSM-1820-25</b>   | 24.0 | +0.124                         | 27.0 | 25.0      | <b>GSM-2427-25</b>  |
| 18.0 | +0.102                         | 20.0 | 34.0      | <b>GSM-1820-34</b>   | 24.0 |                                | 27.0 | 30.0      | <b>GSM-2427-30</b>  |
| 18.0 |                                | 20.0 | 38.0      | <b>GSM-1820-38</b>   | 25.0 | +0.020                         | 26.0 | 23.0      | <b>GSM-2526-23</b>  |
| 18.0 |                                | 20.0 | 45.0      | <b>GSM-1820-45</b>   | 25.0 | +0.072                         | 26.0 | 25.0      | <b>GSM-2526-25</b>  |
| 18.0 |                                | 22.0 | 30.0      | <b>GSM-1822-30</b>   | 25.0 |                                | 28.0 | 12.0      | <b>GSM-2528-12</b>  |
| 19.0 | +0.040                         | 22.0 | 6.0       | <b>GSM-1922-06</b>   | 25.0 |                                | 28.0 | 15.0      | <b>GSM-2528-15</b>  |
| 19.0 | +0.124                         | 22.0 | 28.0      | <b>GSM-1922-28</b>   | 25.0 |                                | 28.0 | 20.0      | <b>GSM-2528-20</b>  |
| 19.0 |                                | 22.0 | 35.0      | <b>GSM-1922-35</b>   | 25.0 |                                | 28.0 | 24.0      | <b>GSM-2528-24</b>  |
| 20.0 | +0.020                         | 21.0 | 20.0      | <b>GSM-2021-20</b>   | 25.0 |                                | 28.0 | 25.0      | <b>GSM-2528-25</b>  |
| 20.0 | +0.072                         |      |           |                      | 25.0 |                                | 28.0 | 30.0      | <b>GSM-2528-30</b>  |
| 20.0 |                                | 22.0 | 3.0       | <b>GSM-2022-03</b>   | 25.0 |                                | 28.0 | 35.0      | <b>GSM-2528-35</b>  |
| 20.0 |                                | 22.0 | 8.0       | <b>GSM-2022-08</b>   | 25.0 |                                | 28.0 | 50.0      | <b>GSM-2528-50</b>  |
| 20.0 |                                | 22.0 | 10.5      | <b>GSM-2022-105</b>  | 26.0 | +0.040                         | 30.0 | 16.0      | <b>GSM-2630-16</b>  |
| 20.0 |                                | 22.0 | 15.0      | <b>GSM-2022-15</b>   | 27.0 | +0.124                         | 30.0 | 5.0       | <b>GSM-2730-05</b>  |
| 20.0 |                                | 22.0 | 20.0      | <b>GSM-2022-20</b>   | 28.0 |                                | 32.0 | 10.5      | <b>GSM-2832-105</b> |
| 20.0 |                                | 22.0 | 22.0      | <b>GSM-2022-22</b>   | 28.0 |                                | 32.0 | 12.0      | <b>GSM-2832-12</b>  |
| 20.0 |                                | 22.0 | 28.0      | <b>GSM-2022-28</b>   | 28.0 |                                | 32.0 | 15.0      | <b>GSM-2832-15</b>  |
| 20.0 |                                | 22.0 | 30.0      | <b>GSM-2022-30</b>   | 28.0 |                                | 32.0 | 20.0      | <b>GSM-2832-20</b>  |
| 20.0 |                                | 22.0 | 47.0      | <b>GSM-2022-47</b>   | 28.0 |                                | 32.0 | 23.0      | <b>GSM-2832-23</b>  |
| 20.0 |                                | 23.0 | 4.5       | <b>GSM-2023-045</b>  | 28.0 |                                | 32.0 | 25.0      | <b>GSM-2832-25</b>  |
| 20.0 |                                | 23.0 | 10.0      | <b>GSM-2023-10</b>   | 28.0 |                                | 32.0 | 30.0      | <b>GSM-2832-30</b>  |
| 20.0 |                                | 23.0 | 15.0      | <b>GSM-2023-15</b>   | 28.0 | +0.065                         | 35.0 | 19.0      | <b>GSM-2835-19</b>  |
| 20.0 |                                | 23.0 | 20.0      | <b>GSM-2023-20</b>   | 28.0 | +0.195                         | 35.0 | 28.0      | <b>GSM-2835-28</b>  |
| 20.0 |                                | 23.0 | 24.0      | <b>GSM-2023-24</b>   | 29.0 | +0.040                         | 33.0 | 6.0       | <b>GSM-2933-06</b>  |
| 20.0 | +0.040                         | 23.0 | 25.0      | <b>GSM-2023-25</b>   | 29.0 | +0.124                         |      |           |                     |
| 20.0 | +0.124                         | 23.0 | 30.0      | <b>GSM-2023-30</b>   | 30.0 | +0.020                         | 31.0 | 5.0       | <b>GSM-3031-05</b>  |
| 20.0 |                                | 23.0 | 35.0      | <b>GSM-2023-35</b>   | 30.0 | +0.072                         | 31.0 | 12.0      | <b>GSM-3031-12</b>  |
| 22.0 |                                | 24.0 | 8.0       | <b>GSM-2224-08</b>   | 30.0 |                                | 31.0 | 30.0      | <b>GSM-3031-30</b>  |
| 22.0 |                                | 24.0 | 10.0      | <b>GSM-2224-10</b>   | 30.0 |                                | 34.0 | 12.0      | <b>GSM-3034-12</b>  |
| 22.0 |                                | 24.0 | 12.0      | <b>GSM-2224-12</b>   | 30.0 |                                | 34.0 | 15.0      | <b>GSM-3034-15</b>  |
| 22.0 |                                | 24.0 | 15.0      | <b>GSM-2224-15</b>   | 30.0 |                                | 34.0 | 20.0      | <b>GSM-3034-20</b>  |
| 22.0 |                                | 24.0 | 17.0      | <b>GSM-2224-17</b>   | 30.0 |                                | 34.0 | 24.0      | <b>GSM-3034-24</b>  |
| 22.0 |                                | 24.0 | 20.0      | <b>GSM-2224-20</b>   | 30.0 | +0.040                         | 34.0 | 25.0      | <b>GSM-3034-25</b>  |
| 22.0 |                                | 24.0 | 30.0      | <b>GSM-2224-30</b>   | 30.0 | +0.124                         | 34.0 | 30.0      | <b>GSM-3034-30</b>  |
| 22.0 |                                | 24.0 | 48.0      | <b>GSM-2224-48</b>   | 30.0 |                                | 34.0 | 35.0      | <b>GSM-3034-35</b>  |
| 22.0 |                                | 25.0 | 15.0      | <b>GSM-2225-15</b>   | 30.0 |                                | 34.0 | 40.0      | <b>GSM-3034-40</b>  |
| 22.0 |                                | 25.0 | 20.0      | <b>GSM-2225-20</b>   | 30.0 |                                | 34.0 | 52.5      | <b>GSM-3034-525</b> |
| 22.0 |                                | 25.0 | 25.0      | <b>GSM-2225-25</b>   | 32.0 |                                | 36.0 | 15.0      | <b>GSM-3236-15</b>  |
| 22.0 |                                | 25.0 | 30.0      | <b>GSM-2225-30</b>   | 32.0 |                                | 36.0 | 20.0      | <b>GSM-3236-20</b>  |
| 22.0 |                                | 25.0 | 38.5      | <b>GSM-2225-38.5</b> | 32.0 | +0.050                         | 36.0 | 30.0      | <b>GSM-3236-30</b>  |
| 24.0 | +0.020 +0.072                  | 25.0 | 25.0      | <b>GSM-2425-25</b>   | 32.0 | +0.150                         | 36.0 | 40.0      | <b>GSM-3236-40</b>  |
| 24.0 | +0.040                         | 27.0 | 6.0       | <b>GSM-2427-06</b>   | 35.0 |                                | 39.0 | 14.0      | <b>GSM-3539-14</b>  |
| 24.0 | +0.124                         | 27.0 | 15.0      | <b>GSM-2427-15</b>   | 35.0 |                                | 39.0 | 20.0      | <b>GSM-3539-20</b>  |

<sup>3)</sup> After press-fit. Testing methods ► Page 57



## Sleeve bearing (Form S)

### Dimensions [mm]

| d1   | d1-<br>Tolerance <sup>3)</sup> | d2   | b1<br>h13 | Part No.            | d1    | d1-<br>Tolerance <sup>3)</sup> | d2    | b1<br>h13 | Part No.               |
|------|--------------------------------|------|-----------|---------------------|-------|--------------------------------|-------|-----------|------------------------|
| 35.0 |                                | 39.0 | 25.0      | <b>GSM-3539-25</b>  | 60.0  |                                | 65.0  | 30.0      | <b>GSM-6065-30</b>     |
| 35.0 |                                | 39.0 | 30.0      | <b>GSM-3539-30</b>  | 60.0  |                                | 65.0  | 40.0      | <b>GSM-6065-40</b>     |
| 35.0 |                                | 39.0 | 40.0      | <b>GSM-3539-40</b>  | 60.0  | +0.060                         | 65.0  | 50.0      | <b>GSM-6065-50</b>     |
| 35.0 |                                | 39.0 | 50.0      | <b>GSM-3539-50</b>  | 60.0  | +0.180                         | 65.0  | 60.0      | <b>GSM-6065-60</b>     |
| 35.0 |                                | 41.0 | 50.0      | <b>GSM-3541-50</b>  | 60.0  |                                | 65.0  | 70.0      | <b>GSM-6065-70</b>     |
| 36.0 |                                | 40.0 | 20.0      | <b>GSM-3640-20</b>  | 62.0  | +0.100                         | 67.0  | 35.0      | <b>GSM-6267-35</b>     |
| 37.0 |                                | 41.0 | 20.0      | <b>GSM-3741-20</b>  | 62.0  | +0.250                         | 67.0  | 72.0      | <b>GSM-6267-72</b>     |
| 38.0 |                                | 42.0 | 25.0      | <b>GSM-3842-25</b>  | 62.0  |                                | 67.0  | 72.0      | <b>GSM-6267-72</b>     |
| 40.0 |                                | 44.0 | 10.0      | <b>GSM-4044-10</b>  | 65.0  |                                | 70.0  | 30.0      | <b>GSM-6570-30</b>     |
| 40.0 |                                | 44.0 | 16.5      | <b>GSM-4044-16</b>  | 65.0  |                                | 70.0  | 50.0      | <b>GSM-6570-50</b>     |
| 40.0 |                                | 44.0 | 20.0      | <b>GSM-4044-20</b>  | 65.0  |                                | 70.0  | 104.0     | <b>GSM-6570-104</b>    |
| 40.0 |                                | 44.0 | 30.0      | <b>GSM-4044-30</b>  | 68.0  |                                | 73.0  | 60.0      | <b>GSM-6873-60</b>     |
| 40.0 |                                | 44.0 | 40.0      | <b>GSM-4044-40</b>  | 70.0  | +0.060                         | 75.0  | 60.0      | <b>GSM-7075-60</b>     |
| 40.0 |                                | 44.0 | 50.0      | <b>GSM-4044-50</b>  | 72.0  | +0.180                         | 77.0  | 24.5      | <b>GSM-7277-24.5</b>   |
| 40.0 |                                | 44.0 | 52.5      | <b>GSM-4044-525</b> | 72.0  |                                | 77.0  | 76.0      | <b>GSM-7277-76</b>     |
| 42.0 | +0.050                         | 46.0 | 40.0      | <b>GSM-4246-40</b>  | 75.0  |                                | 80.0  | 40.0      | <b>GSM-7580-40</b>     |
| 44.0 | +0.150                         | 48.0 | 20.0      | <b>GSM-4448-20</b>  | 75.0  |                                | 80.0  | 60.0      | <b>GSM-7580-60</b>     |
| 45.0 |                                | 50.0 | 10.0      | <b>GSM-4550-10</b>  | 80.0  |                                | 85.0  | 60.0      | <b>GSM-8085-60</b>     |
| 45.0 |                                | 50.0 | 20.0      | <b>GSM-4550-20</b>  | 80.0  |                                | 85.0  | 100.0     | <b>GSM-8085-100</b>    |
| 45.0 |                                | 50.0 | 22.0      | <b>GSM-4550-22</b>  | 85.0  |                                | 90.0  | 100.0     | <b>GSM-8590-100</b>    |
| 45.0 |                                | 50.0 | 23.5      | <b>GSM-4550-235</b> | 90.0  |                                | 95.0  | 100.0     | <b>GSM-9095-100</b>    |
| 45.0 |                                | 50.0 | 30.0      | <b>GSM-4550-30</b>  | 95.0  |                                | 100.0 | 100.0     | <b>GSM-95100-100</b>   |
| 45.0 |                                | 50.0 | 38.0      | <b>GSM-4550-38</b>  | 100.0 |                                | 105.0 | 21.5      | <b>GSM-100105-21.5</b> |
| 45.0 |                                | 50.0 | 40.0      | <b>GSM-4550-40</b>  | 100.0 | +0.072                         | 105.0 | 30.0      | <b>GSM-100105-30</b>   |
| 45.0 |                                | 50.0 | 50.0      | <b>GSM-4550-50</b>  | 100.0 | +0.212                         | 105.0 | 32.0      | <b>GSM-100105-32</b>   |
| 50.0 |                                | 55.0 | 20.0      | <b>GSM-5055-20</b>  | 100.0 |                                | 105.0 | 100.0     | <b>GSM-100105-100</b>  |
| 50.0 |                                | 55.0 | 25.0      | <b>GSM-5055-25</b>  | 105.0 |                                | 110.0 | 100.0     | <b>GSM-105110-100</b>  |
| 50.0 |                                | 55.0 | 30.0      | <b>GSM-5055-30</b>  | 110.0 |                                | 115.0 | 100.0     | <b>GSM-110115-100</b>  |
| 50.0 |                                | 55.0 | 40.0      | <b>GSM-5055-40</b>  | 120.0 |                                | 125.0 | 100.0     | <b>GSM-120125-100</b>  |
| 50.0 |                                | 55.0 | 50.0      | <b>GSM-5055-50</b>  | 125.0 |                                | 130.0 | 100.0     | <b>GSM-125130-100</b>  |
| 50.0 |                                | 55.0 | 60.0      | <b>GSM-5055-60</b>  | 130.0 |                                | 135.0 | 100.0     | <b>GSM-130135-100</b>  |
| 52.0 |                                | 57.0 | 20.0      | <b>GSM-5257-20</b>  | 135.0 | +0.085                         | 140.0 | 80.0      | <b>GSM-135140-80</b>   |
| 55.0 | +0.060                         | 60.0 | 20.0      | <b>GSM-5560-20</b>  | 140.0 | +0.245                         | 145.0 | 100.0     | <b>GSM-140145-100</b>  |
| 55.0 | +0.180                         | 60.0 | 40.0      | <b>GSM-5560-40</b>  | 140.0 |                                | 145.0 | 104.0     | <b>GSM-140145-104</b>  |
| 55.0 |                                | 60.0 | 50.0      | <b>GSM-5560-50</b>  | 150.0 |                                | 155.0 | 100.0     | <b>GSM-150155-100</b>  |
| 55.0 |                                | 60.0 | 60.0      | <b>GSM-5560-60</b>  |       |                                |       |           |                        |

<sup>3)</sup> After press-fit. Testing methods ► Page 57

## Flange bearing (Form F)

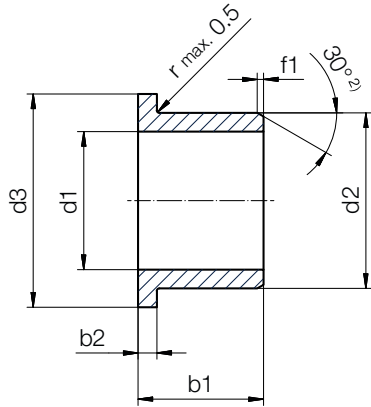

<sup>2)</sup> Thickness < 1 mm: chamfer = 20°

Chamfer in relation to the d1

|          |       |        |         |        |
|----------|-------|--------|---------|--------|
| d1 [mm]: | Ø 1-6 | Ø 6-12 | Ø 12-30 | Ø > 30 |
| f [mm]:  | 0.3   | 0.5    | 0.8     | 1.2    |

## Dimensions [mm]

| d1  | d1-<br>Tolerance <sup>3)</sup> | d2  | d3<br>d13 | b1<br>h13 | b2<br>-0.14 | Part No.             |
|-----|--------------------------------|-----|-----------|-----------|-------------|----------------------|
| 3.0 |                                | 4.5 | 7.5       | 2.0       | 0.5         | <b>GFM-0304-02</b>   |
| 3.0 |                                | 4.5 | 7.0       | 2.7       | 0.75        | <b>GFM-0304-0275</b> |
| 3.0 | +0.014                         | 4.5 | 7.5       | 3.0       | 0.75        | <b>GFM-0304-03</b>   |
| 3.0 | +0.054                         | 4.5 | 7.5       | 5.0       | 0.75        | <b>GFM-0304-05</b>   |
| 3.0 |                                | 4.5 | 7.0       | 5.0       | 0.75        | <b>GFM-030407-05</b> |
| 4.0 | +0.010                         | 5.0 | 9.5       | 4.0       | 0.5         | <b>GFM-04050-04</b>  |
| 4.0 | +0.040                         | 5.0 | 9.5       | 6.0       | 0.5         | <b>GFM-04050-06</b>  |
| 4.0 |                                | 5.5 | 9.5       | 2.5       | 0.75        | <b>GFM-0405-0255</b> |
| 4.0 |                                | 5.5 | 9.5       | 3.0       | 0.75        | <b>GFM-0405-03</b>   |
| 4.0 | +0.020                         | 5.5 | 9.5       | 4.0       | 0.75        | <b>GFM-0405-04</b>   |
| 4.0 | +0.068                         | 5.5 | 9.5       | 6.0       | 0.75        | <b>GFM-0405-06</b>   |
| 4.0 |                                | 5.5 | 8.0       | 10.0      | 1.0         | <b>GFM-040508-10</b> |
| 5.0 |                                | 6.0 | 10.0      | 3.5       | 0.5         | <b>GFM-0506-035</b>  |
| 5.0 |                                | 6.0 | 10.0      | 4.0       | 0.5         | <b>GFM-0506-04</b>   |
| 5.0 | +0.010                         | 6.0 | 10.0      | 5.0       | 0.5         | <b>GFM-0506-05</b>   |
| 5.0 | +0.040                         | 6.0 | 10.0      | 6.0       | 0.5         | <b>GFM-0506-06</b>   |
| 5.0 |                                | 6.0 | 10.0      | 15.3      | 0.5         | <b>GFM-0506-15</b>   |
| 5.0 |                                | 7.0 | 11.0      | 3.5       | 1.0         | <b>GFM-0507-03</b>   |
| 5.0 |                                | 7.0 | 11.0      | 4.0       | 1.0         | <b>GFM-0507-04</b>   |
| 5.0 |                                | 7.0 | 11.0      | 5.0       | 1.0         | <b>GFM-0507-05</b>   |
| 5.0 |                                | 7.0 | 11.0      | 7.0       | 1.0         | <b>GFM-0507-07</b>   |
| 5.0 | +0.020                         | 7.0 | 11.0      | 11.0      | 1.0         | <b>GFM-0507-11</b>   |
| 5.0 | +0.068                         | 7.0 | 11.0      | 14.5      | 1.0         | <b>GFM-0507-145</b>  |
| 5.0 |                                | 7.0 | 11.0      | 30.0      | 1.0         | <b>GFM-0507-30</b>   |
| 5.0 |                                | 7.0 | 9.5       | 5.0       | 1.0         | <b>GFM-050709-05</b> |
| 5.0 |                                | 7.0 | 15.0      | 4.0       | 1.0         | <b>GFM-050715-04</b> |
| 6.0 | +0.010                         | 7.0 | 11.0      | 2.4       | 0.5         | <b>GFM-0607-024</b>  |
| 6.0 | +0.040                         | 7.0 | 11.0      | 4.5       | 0.5         | <b>GFM-0607-045</b>  |

<sup>3)</sup> After press-fit. Testing methods ► Page 57

## Order key

Type      Dimensions [mm]

**G F M -03 04 -02**

|                   |        |        |            |            |           |
|-------------------|--------|--------|------------|------------|-----------|
| iglidur® material | Form F | Metric | Inner-Ø d1 | Outer-Ø d2 | Length b1 |
|-------------------|--------|--------|------------|------------|-----------|

Dimensions according to ISO 3547-1 and special dimensions

Imperial dimensions available  
► From page 1428

| d1  | d1-<br>Tolerance <sup>3)</sup> | d2  | d3<br>d13 | b1<br>h13 | b2<br>-0.14 | Part No.              |
|-----|--------------------------------|-----|-----------|-----------|-------------|-----------------------|
| 6.0 | +0.010                         | 7.0 | 11.0      | 6.0       | 0.5         | <b>GFM-0607-06</b>    |
| 6.0 | +0.040                         | 7.0 | 11.0      | 10.0      | 0.5         | <b>GFM-0607-10</b>    |
| 6.0 |                                | 8.0 | 12.0      | 2.5       | 1.0         | <b>GFM-0608-025</b>   |
| 6.0 |                                | 8.0 | 12.0      | 4.0       | 1.0         | <b>GFM-0608-04</b>    |
| 6.0 |                                | 8.0 | 12.0      | 4.8       | 1.0         | <b>GFM-0608-048</b>   |
| 6.0 |                                | 8.0 | 12.0      | 5.0       | 1.0         | <b>GFM-0608-05</b>    |
| 6.0 |                                | 8.0 | 12.0      | 6.0       | 1.0         | <b>GFM-0608-06</b>    |
| 6.0 | +0.020                         | 8.0 | 12.0      | 7.0       | 1.0         | <b>GFM-0608-07</b>    |
| 6.0 | +0.068                         | 8.0 | 12.0      | 8.0       | 1.0         | <b>GFM-0608-08</b>    |
| 6.0 |                                | 8.0 | 12.0      | 10.0      | 1.0         | <b>GFM-0608-10</b>    |
| 6.0 |                                | 8.0 | 12.0      | 25.0      | 1.0         | <b>GFM-0608-25</b>    |
| 6.0 |                                | 8.0 | 12.0      | 35.0      | 1.0         | <b>GFM-0608-35</b>    |
| 6.0 |                                | 8.0 | 14.0      | 2.8       | 1.0         | <b>GFM-060814-028</b> |
| 6.0 |                                | 8.0 | 14.0      | 12.0      | 1.0         | <b>GFM-060814-12</b>  |
| 7.0 |                                | 8.0 | 12.0      | 1.7       | 0.5         | <b>GFM-0708-017</b>   |
| 7.0 | +0.013                         | 8.0 | 12.0      | 3.0       | 0.5         | <b>GFM-0708-03</b>    |
| 7.0 | +0.049                         | 8.0 | 12.0      | 6.0       | 0.5         | <b>GFM-0708-06</b>    |
| 7.0 |                                | 8.0 | 12.0      | 8.0       | 0.5         | <b>GFM-0708-08</b>    |
| 7.0 |                                | 9.0 | 15.0      | 3.5       | 1.0         | <b>GFM-0709-035</b>   |
| 7.0 |                                | 9.0 | 15.0      | 6.0       | 1.0         | <b>GFM-0709-06</b>    |
| 7.0 | +0.025                         | 9.0 | 15.0      | 10.0      | 1.0         | <b>GFM-0709-10</b>    |
| 7.0 | +0.083                         | 9.0 | 15.0      | 12.0      | 1.0         | <b>GFM-0709-12</b>    |
| 7.0 |                                | 9.0 | 19.0      | 10.0      | 1.0         | <b>GFM-070919-10</b>  |
| 8.0 |                                | 9.0 | 15.0      | 3.0       | 0.5         | <b>GFM-0809-03</b>    |
| 8.0 |                                | 9.0 | 13.0      | 3.5       | 0.5         | <b>GFM-0809-035</b>   |
| 8.0 | +0.013                         | 9.0 | 13.0      | 5.5       | 0.5         | <b>GFM-0809-055</b>   |
| 8.0 | +0.049                         | 9.0 | 13.0      | 8.0       | 0.5         | <b>GFM-0809-08</b>    |
| 8.0 |                                | 9.0 | 13.0      | 12.0      | 0.5         | <b>GFM-0809-12</b>    |

## Flange bearing (Form F)

### Dimensions [mm]

| d1   | d1-<br>Tolerance <sup>3)</sup> | d2   | d3<br>d13 | b1<br>h13 | b2<br>-0.14 | Part No.              |
|------|--------------------------------|------|-----------|-----------|-------------|-----------------------|
| 8.0  |                                | 10.0 | 15.0      | 3.0       | 1.0         | <b>GFM-0810-03</b>    |
| 8.0  |                                | 10.0 | 15.0      | 4.0       | 1.0         | <b>GFM-0810-04</b>    |
| 8.0  |                                | 10.0 | 15.0      | 5.5       | 1.0         | <b>GFM-0810-05</b>    |
| 8.0  |                                | 10.0 | 15.0      | 6.5       | 1.0         | <b>GFM-0810-065</b>   |
| 8.0  |                                | 10.0 | 15.0      | 7.5       | 1.0         | <b>GFM-0810-07</b>    |
| 8.0  |                                | 10.0 | 15.0      | 9.5       | 1.0         | <b>GFM-0810-09</b>    |
| 8.0  | +0.025                         | 10.0 | 15.0      | 10.0      | 1.0         | <b>GFM-0810-10</b>    |
| 8.0  | +0.083                         | 10.0 | 14.0      | 11.0      | 1.0         | <b>GFM-0810-11</b>    |
| 8.0  |                                | 10.0 | 15.0      | 15.0      | 1.0         | <b>GFM-0810-15</b>    |
| 8.0  |                                | 10.0 | 15.0      | 25.0      | 1.0         | <b>GFM-0810-25</b>    |
| 8.0  |                                | 10.0 | 15.0      | 30.0      | 1.0         | <b>GFM-0810-30</b>    |
| 8.0  |                                | 10.0 | 12.0      | 12.5      | 1.0         | <b>GFM-081012-125</b> |
| 8.0  |                                | 10.0 | 13.0      | 8.0       | 1.0         | <b>GFM-081013-08</b>  |
| 8.0  | +0.040<br>+0.098               | 10.0 | 14.0      | 5.0       | 1.0         | <b>GFM-081014-05</b>  |
| 8.0  | +0.025                         | 10.0 | 14.0      | 6.0       | 1.0         | <b>GFM-081014-06</b>  |
| 8.0  | +0.083                         | 10.0 | 14.0      | 8.0       | 1.0         | <b>GFM-081014-08</b>  |
| 8.0  | +0.040<br>+0.098               | 10.0 | 14.0      | 10.0      | 1.0         | <b>GFM-081014-10</b>  |
| 8.0  |                                | 10.0 | 16.0      | 11.5      | 1.5         | <b>GFM-081016-11</b>  |
| 8.0  | +0.025                         | 10.0 | 16.0      | 15.0      | 1.5         | <b>GFM-081016-15</b>  |
| 8.0  | +0.083                         | 10.0 | 17.0      | 15.0      | 1.0         | <b>GFM-081017-15</b>  |
| 8.0  |                                | 10.0 | 18.0      | 3.0       | 1.0         | <b>GFM-081018-03</b>  |
| 8.0  | +0.040                         | 12.0 | 16.0      | 6.0       | 2.0         | <b>GFM-0812-06</b>    |
| 8.0  | +0.130                         | 12.0 | 21.0      | 8.0       | 2.0         | <b>GFM-081221-08</b>  |
| 9.0  | +0.013                         | 10.0 | 15.0      | 6.5       | 0.5         | <b>GFM-0910-065</b>   |
| 9.0  | +0.049                         | 10.0 | 15.0      | 17.5      | 0.5         | <b>GFM-0910-17</b>    |
| 10.0 | +0.013<br>+0.046               | 11.0 | 20.0      | 3.5       | 0.5         | <b>GFM-1011-03</b>    |
| 10.0 | +0.013                         | 11.0 | 15.0      | 4.4       | 0.5         | <b>GFM-1011-044</b>   |
| 10.0 | +0.049                         | 11.0 | 15.0      | 10.0      | 0.5         | <b>GFM-1011-10</b>    |
| 10.0 |                                | 12.0 | 18.0      | 3.5       | 1.0         | <b>GFM-1012-035</b>   |
| 10.0 |                                | 12.0 | 18.0      | 4.0       | 1.0         | <b>GFM-1012-04</b>    |
| 10.0 |                                | 12.0 | 18.0      | 5.0       | 1.0         | <b>GFM-1012-05</b>    |
| 10.0 |                                | 12.0 | 18.0      | 6.0       | 1.0         | <b>GFM-1012-06</b>    |
| 10.0 |                                | 12.0 | 18.0      | 7.0       | 1.0         | <b>GFM-1012-07</b>    |
| 10.0 |                                | 12.0 | 18.0      | 9.0       | 1.0         | <b>GFM-1012-09</b>    |
| 10.0 | +0.025                         | 12.0 | 18.0      | 10.0      | 1.0         | <b>GFM-1012-10</b>    |
| 10.0 | +0.083                         | 12.0 | 18.0      | 12.0      | 1.0         | <b>GFM-1012-12</b>    |
| 10.0 |                                | 12.0 | 18.0      | 15.0      | 1.0         | <b>GFM-1012-15</b>    |
| 10.0 |                                | 12.0 | 18.0      | 17.0      | 1.0         | <b>GFM-1012-17</b>    |
| 10.0 |                                | 12.0 | 15.0      | 12.0      | 1.0         | <b>GFM-101215-12</b>  |
| 10.0 |                                | 12.0 | 16.0      | 6.0       | 1.0         | <b>GFM-101216-06</b>  |
| 10.0 |                                | 12.0 | 16.0      | 9.0       | 1.0         | <b>GFM-101216-09</b>  |
| 10.0 |                                | 12.0 | 16.0      | 15.0      | 1.0         | <b>GFM-101216-15</b>  |

| d1   | d1-<br>Tolerance <sup>3)</sup> | d2   | d3<br>d13 | b1<br>h13 | b2<br>-0.14 | Part No.             |
|------|--------------------------------|------|-----------|-----------|-------------|----------------------|
| 11.0 |                                | 12.0 | 16.0      | 6.0       | 0.5         | <b>GFM-1112-06</b>   |
| 12.0 | +0.016                         | 13.0 | 17.0      | 3.0       | 0.5         | <b>GFM-1213-03</b>   |
| 12.0 | +0.059                         | 13.0 | 15.0      | 12.0      | 0.5         | <b>GFM-121315-12</b> |
| 12.0 |                                | 13.0 | 17.0      | 12.0      | 0.5         | <b>GFM-1213-12</b>   |
| 12.0 |                                | 14.0 | 20.0      | 3.0       | 1.0         | <b>GFM-1214-03</b>   |
| 12.0 |                                | 14.0 | 20.0      | 5.0       | 1.0         | <b>GFM-1214-05</b>   |
| 12.0 |                                | 14.0 | 20.0      | 6.0       | 1.0         | <b>GFM-1214-06</b>   |
| 12.0 |                                | 14.0 | 20.0      | 7.0       | 1.0         | <b>GFM-1214-07</b>   |
| 12.0 |                                | 14.0 | 20.0      | 9.0       | 1.0         | <b>GFM-1214-09</b>   |
| 12.0 |                                | 14.0 | 20.0      | 10.0      | 1.0         | <b>GFM-1214-10</b>   |
| 12.0 |                                | 14.0 | 20.0      | 11.0      | 1.0         | <b>GFM-1214-11</b>   |
| 12.0 |                                | 14.0 | 20.0      | 12.0      | 1.0         | <b>GFM-1214-12</b>   |
| 12.0 |                                | 14.0 | 20.0      | 15.0      | 1.0         | <b>GFM-1214-15</b>   |
| 12.0 |                                | 14.0 | 20.0      | 17.0      | 1.0         | <b>GFM-1214-17</b>   |
| 12.0 |                                | 14.0 | 20.0      | 20.0      | 1.0         | <b>GFM-1214-20</b>   |
| 12.0 |                                | 14.0 | 20.0      | 24.0      | 1.0         | <b>GFM-1214-24</b>   |
| 12.0 |                                | 14.0 | 20.0      | 31.0      | 1.0         | <b>GFM-1214-31</b>   |
| 12.0 |                                | 14.0 | 20.0      | 40.0      | 1.0         | <b>GFM-1214-40</b>   |
| 12.0 |                                | 14.0 | 18.0      | 4.0       | 1.0         | <b>GFM-121418-04</b> |
| 12.0 | +0.032<br>+0.102               | 14.0 | 18.0      | 8.0       | 1.0         | <b>GFM-121418-08</b> |
| 12.0 |                                | 14.0 | 18.0      | 10.0      | 1.0         | <b>GFM-121418-10</b> |
| 12.0 |                                | 14.0 | 18.0      | 12.0      | 1.0         | <b>GFM-121418-12</b> |
| 12.0 |                                | 14.0 | 18.0      | 15.0      | 1.0         | <b>GFM-121418-15</b> |
| 12.0 |                                | 14.0 | 18.0      | 20.0      | 1.0         | <b>GFM-121418-20</b> |
| 13.0 |                                | 15.0 | 22.0      | 6.0       | 1.0         | <b>GFM-1315-06</b>   |
| 13.0 |                                | 15.0 | 22.0      | 8.0       | 1.0         | <b>GFM-1315-08</b>   |
| 13.0 |                                | 15.0 | 22.0      | 40.0      | 1.0         | <b>GFM-131522-40</b> |
| 14.0 |                                | 16.0 | 22.0      | 3.0       | 1.0         | <b>GFM-1416-03</b>   |
| 14.0 |                                | 16.0 | 22.0      | 4.0       | 1.0         | <b>GFM-1416-04</b>   |
| 14.0 |                                | 16.0 | 22.0      | 6.0       | 1.0         | <b>GFM-1416-06</b>   |
| 14.0 |                                | 16.0 | 22.0      | 8.0       | 1.0         | <b>GFM-1416-08</b>   |
| 14.0 |                                | 16.0 | 22.0      | 10.0      | 1.0         | <b>GFM-1416-10</b>   |
| 14.0 |                                | 16.0 | 22.0      | 12.0      | 1.0         | <b>GFM-1416-12</b>   |
| 14.0 |                                | 16.0 | 22.0      | 17.0      | 1.0         | <b>GFM-1416-17</b>   |
| 14.0 |                                | 16.0 | 22.0      | 21.0      | 1.0         | <b>GFM-1416-21</b>   |
| 15.0 |                                | 16.0 | 20.0      | 2.0       | 0.5         | <b>GFM-1516-02</b>   |
| 15.0 | +0.016                         | 16.0 | 20.0      | 2.5       | 0.5         | <b>GFM-1516-025</b>  |
| 15.0 | +0.059                         | 16.0 | 20.0      | 3.0       | 0.5         | <b>GFM-1516-03</b>   |
| 15.0 |                                | 16.0 | 20.0      | 15.0      | 0.5         | <b>GFM-1516-15</b>   |
| 15.0 |                                | 17.0 | 23.0      | 4.0       | 1.0         | <b>GFM-1517-04</b>   |
| 15.0 |                                | 17.0 | 23.0      | 4.5       | 1.0         | <b>GFM-1517-045</b>  |
| 15.0 | +0.032                         | 17.0 | 23.0      | 5.0       | 1.0         | <b>GFM-1517-05</b>   |
| 15.0 | +0.102                         | 17.0 | 23.0      | 9.0       | 1.0         | <b>GFM-1517-09</b>   |
| 15.0 |                                | 17.0 | 23.0      | 12.0      | 1.0         | <b>GFM-1517-12</b>   |
| 15.0 |                                | 17.0 | 23.0      | 17.0      | 1.0         | <b>GFM-1517-17</b>   |

<sup>3)</sup> After press-fit. Testing methods ► Page 57

## Flange bearing (Form F)

## Dimensions [mm]

| d1   | d1-<br>Tolerance <sup>3)</sup> | d2   | d3   | b1   | b2    | Part No.       | d1   | d1-<br>Tolerance <sup>3)</sup> | d2   | d3   | b1   | b2    | Part No.      |
|------|--------------------------------|------|------|------|-------|----------------|------|--------------------------------|------|------|------|-------|---------------|
|      |                                |      | d13  | h13  | -0.14 |                |      |                                |      | d13  | h13  | -0.14 |               |
| 15.0 |                                | 17.0 | 23.0 | 20.0 | 1.0   | GFM-1517-20    | 25.0 |                                | 27.0 | 32.0 | 7.0  | 1.0   | GFM-2527-07   |
| 15.0 |                                | 18.0 | 24.0 | 32.0 | 1.5   | GFM-151824-32  | 25.0 |                                | 27.0 | 32.0 | 48.0 | 1.0   | GFM-2527-48   |
| 16.0 |                                | 18.0 | 24.0 | 4.0  | 1.0   | GFM-1618-04    | 25.0 |                                | 28.0 | 35.0 | 11.5 | 1.5   | GFM-2528-11   |
| 16.0 |                                | 18.0 | 24.0 | 5.0  | 1.0   | GFM-1618-05    | 25.0 |                                | 28.0 | 35.0 | 16.5 | 1.5   | GFM-2528-16   |
| 16.0 |                                | 18.0 | 24.0 | 6.0  | 1.0   | GFM-1618-06    | 25.0 |                                | 28.0 | 35.0 | 21.5 | 1.5   | GFM-2528-21   |
| 16.0 |                                | 18.0 | 24.0 | 9.0  | 1.0   | GFM-1618-09    | 25.0 |                                | 28.0 | 30.0 | 10.0 | 1.5   | GFM-252830-10 |
| 16.0 |                                | 18.0 | 24.0 | 12.0 | 1.0   | GFM-1618-12    | 26.0 |                                | 30.0 | 37.0 | 12.0 | 2.0   | GFM-2630-12   |
| 16.0 |                                | 18.0 | 24.0 | 16.0 | 1.0   | GFM-1618-16    | 27.0 |                                | 30.0 | 38.0 | 20.0 | 1.5   | GFM-2730-20   |
| 16.0 |                                | 18.0 | 24.0 | 17.0 | 1.0   | GFM-1618-17    | 28.0 |                                | 30.0 | 36.0 | 10.0 | 1.0   | GFM-2830-10   |
| 16.0 |                                | 18.0 | 24.0 | 21.0 | 1.0   | GFM-1618-21    | 28.0 |                                | 30.0 | 35.0 | 36.0 | 1.0   | GFM-2830-36   |
| 17.0 |                                | 19.0 | 25.0 | 9.0  | 1.0   | GFM-1719-09    | 28.0 |                                | 30.0 | 35.0 | 48.0 | 1.0   | GFM-2830-48   |
| 17.0 | +0.032                         | 19.0 | 25.0 | 16.0 | 1.0   | GFM-1719-16    | 28.0 |                                | 30.0 | 36.0 | 31.0 | 1.0   | GFM-283036-31 |
| 17.0 | +0.102                         | 19.0 | 25.0 | 25.0 | 1.0   | GFM-1719-25    | 28.0 | +0.040                         | 32.0 | 39.0 | 20.0 | 2.0   | GFM-283239-20 |
| 18.0 |                                | 20.0 | 26.0 | 4.0  | 1.0   | GFM-1820-04    | 28.0 | +0.124                         | 32.0 | 50.0 | 35.0 | 2.0   | GFM-283250-35 |
| 18.0 |                                | 20.0 | 26.0 | 6.0  | 1.0   | GFM-1820-06    | 30.0 |                                | 31.0 | 36.0 | 20.0 | 0.5   | GFM-3031-20   |
| 18.0 |                                | 20.0 | 26.0 | 9.0  | 1.0   | GFM-1820-09    | 30.0 |                                | 31.0 | 35.0 | 30.0 | 0.5   | GFM-3031-30   |
| 18.0 |                                | 20.0 | 26.0 | 11.0 | 1.0   | GFM-1820-11    | 30.0 |                                | 32.0 | 37.0 | 4.0  | 1.0   | GFM-3032-04   |
| 18.0 |                                | 20.0 | 26.0 | 12.0 | 1.0   | GFM-1820-12    | 30.0 |                                | 32.0 | 37.0 | 12.0 | 1.0   | GFM-3032-12   |
| 18.0 |                                | 20.0 | 26.0 | 17.0 | 1.0   | GFM-1820-17    | 30.0 |                                | 32.0 | 37.0 | 17.5 | 1.0   | GFM-3032-17   |
| 18.0 |                                | 20.0 | 26.0 | 22.0 | 1.0   | GFM-1820-22    | 30.0 |                                | 32.0 | 37.0 | 22.0 | 1.0   | GFM-3032-22   |
| 18.0 |                                | 20.0 | 26.0 | 30.0 | 1.0   | GFM-1820-30    | 30.0 |                                | 34.0 | 42.0 | 9.0  | 2.0   | GFM-3034-09   |
| 18.0 |                                | 20.0 | 26.0 | 32.0 | 1.0   | GFM-1820-32    | 30.0 |                                | 34.0 | 42.0 | 16.0 | 2.0   | GFM-3034-16   |
| 18.0 |                                | 20.0 | 22.0 | 6.0  | 1.0   | GFM-182022-06  | 30.0 |                                | 34.0 | 42.0 | 20.0 | 2.0   | GFM-3034-20   |
| 18.0 |                                | 22.0 | 26.0 | 28.0 | 2.0   | GFM-1822-28    | 30.0 |                                | 34.0 | 42.0 | 26.0 | 2.0   | GFM-3034-26   |
| 20.0 |                                | 21.0 | 26.0 | 3.5  | 0.5   | GFM-2021-035   | 30.0 |                                | 34.0 | 42.0 | 37.0 | 2.0   | GFM-3034-37   |
| 20.0 | +0.020                         | 21.0 | 25.0 | 15.0 | 0.5   | GFM-2021-15    | 30.0 |                                | 34.0 | 40.0 | 10.0 | 2.0   | GFM-303440-10 |
| 20.0 | +0.072                         | 21.0 | 25.0 | 20.0 | 0.5   | GFM-2021-20    | 32.0 |                                | 36.0 | 40.0 | 16.0 | 2.0   | GFM-3236-16   |
| 20.0 |                                | 23.0 | 30.0 | 7.0  | 1.5   | GFM-2023-07    | 32.0 |                                | 36.0 | 40.0 | 26.0 | 2.0   | GFM-3236-26   |
| 20.0 |                                | 23.0 | 30.0 | 11.5 | 1.5   | GFM-2023-11    | 34.0 |                                | 38.0 | 50.0 | 35.0 | 2.0   | GFM-343850-35 |
| 20.0 |                                | 23.0 | 30.0 | 16.5 | 1.5   | GFM-2023-16    | 35.0 |                                | 39.0 | 47.0 | 5.8  | 2.0   | GFM-3539-058  |
| 20.0 |                                | 23.0 | 30.0 | 21.5 | 1.5   | GFM-2023-21    | 35.0 |                                | 39.0 | 47.0 | 7.0  | 2.0   | GFM-3539-07   |
| 20.0 |                                | 23.0 | 26.0 | 7.0  | 1.5   | GFM-202326-07  | 35.0 |                                | 39.0 | 47.0 | 12.0 | 2.0   | GFM-3539-12   |
| 20.0 |                                | 23.0 | 26.0 | 21.5 | 1.5   | GFM-202326-21  | 35.0 |                                | 39.0 | 47.0 | 16.0 | 2.0   | GFM-3539-16   |
| 20.0 |                                | 23.0 | 28.0 | 15.0 | 1.5   | GFM-202328-15  | 35.0 |                                | 39.0 | 47.0 | 26.0 | 2.0   | GFM-3539-26   |
| 20.0 | +0.040                         | 23.0 | 29.0 | 20.0 | 1.5   | GFM-202329-20  | 35.0 | +0.050                         | 39.0 | 47.0 | 36.0 | 2.0   | GFM-3539-36   |
| 22.0 | +0.124                         | 24.0 | 30.0 | 25.0 | 1.0   | GFM-2224-25    | 38.0 | +0.150                         | 42.0 | 54.0 | 22.0 | 2.0   | GFM-3842-22   |
| 22.0 |                                | 25.0 | 29.0 | 4.5  | 1.5   | GFM-222529-045 | 40.0 |                                | 44.0 | 52.0 | 7.0  | 2.0   | GFM-4044-07   |
| 22.0 |                                | 25.0 | 30.0 | 21.5 | 1.5   | GFM-222530-215 | 40.0 |                                | 44.0 | 52.0 | 14.0 | 2.0   | GFM-4044-14   |
| 22.0 |                                | 25.0 | 30.0 | 25.0 | 1.5   | GFM-222530-25  | 40.0 |                                | 44.0 | 52.0 | 20.0 | 2.0   | GFM-4044-20   |
| 22.0 |                                | 25.0 | 35.0 | 31.5 | 1.5   | GFM-222535-315 | 40.0 |                                | 44.0 | 52.0 | 30.0 | 2.0   | GFM-4044-30   |
| 24.0 |                                | 27.0 | 32.0 | 7.0  | 1.5   | GFM-2427-07    | 40.0 |                                | 44.0 | 52.0 | 40.0 | 2.0   | GFM-4044-40   |
| 24.0 |                                | 27.0 | 32.0 | 10.5 | 1.5   | GFM-2427-10    | 40.0 |                                | 44.0 | 52.0 | 50.0 | 2.0   | GFM-4044-50   |
| 25.0 | +0.020                         | 26.0 | 30.0 | 25.0 | 0.5   | GFM-2526-25    | 40.0 |                                | 46.0 | 50.0 | 20.0 | 2.0   | GFM-4046-20   |
|      | +0.072                         |      |      |      |       |                | 42.0 |                                | 46.0 | 53.0 | 19.0 | 2.0   | GFM-4246-19   |

<sup>3)</sup> After press-fit. Testing methods ► Page 57

## Flange bearing (Form F)

### Dimensions [mm]

| d1   | d1-<br>Tolerance <sup>3)</sup> | d2   | d3<br>d13 | b1<br>h13 | b2<br>-0.14 | Part No.             |
|------|--------------------------------|------|-----------|-----------|-------------|----------------------|
| 45.0 |                                | 50.0 | 58.0      | 25.0      | 2.0         | <b>GFM-4550-25</b>   |
| 45.0 |                                | 50.0 | 58.0      | 30.0      | 2.0         | <b>GFM-4550-30</b>   |
| 45.0 |                                | 50.0 | 58.0      | 50.0      | 2.0         | <b>GFM-4550-50</b>   |
| 50.0 | +0.050                         | 55.0 | 63.0      | 7.0       | 2.0         | <b>GFM-5055-07</b>   |
| 50.0 | +0.150                         | 55.0 | 63.0      | 10.0      | 2.0         | <b>GFM-5055-10</b>   |
| 50.0 |                                | 55.0 | 63.0      | 25.0      | 2.0         | <b>GFM-5055-25</b>   |
| 50.0 |                                | 55.0 | 63.0      | 40.0      | 2.0         | <b>GFM-5055-40</b>   |
| 50.0 |                                | 55.0 | 63.0      | 50.0      | 2.0         | <b>GFM-5055-50</b>   |
| 60.0 |                                | 65.0 | 73.0      | 7.0       | 2.0         | <b>GFM-6065-07</b>   |
| 60.0 |                                | 65.0 | 73.0      | 22.0      | 2.0         | <b>GFM-6065-22</b>   |
| 60.0 |                                | 65.0 | 73.0      | 30.0      | 2.0         | <b>GFM-6065-30</b>   |
| 60.0 |                                | 65.0 | 73.0      | 50.0      | 2.0         | <b>GFM-6065-50</b>   |
| 60.0 | +0.060                         | 65.0 | 80.0      | 62.0      | 2.0         | <b>GFM-606580-62</b> |
| 65.0 | +0.180                         | 70.0 | 78.0      | 50.0      | 2.0         | <b>GFM-6570-50</b>   |
| 70.0 |                                | 75.0 | 83.0      | 50.0      | 2.0         | <b>GFM-7075-50</b>   |
| 70.0 |                                | 75.0 | 83.0      | 85.5      | 2.0         | <b>GFM-7075-855</b>  |
| 75.0 |                                | 80.0 | 88.0      | 50.0      | 2.0         | <b>GFM-7580-50</b>   |

| d1    | d1-<br>Tolerance <sup>3)</sup> | d2    | d3<br>d13 | b1<br>h13 | b2<br>-0.14 | Part No.                |
|-------|--------------------------------|-------|-----------|-----------|-------------|-------------------------|
| 80.0  | +0.060                         | 85.0  | 93.0      | 50.0      | 2.5         | <b>GFM-8085-50</b>      |
| 80.0  | +0.180                         | 85.0  | 93.0      | 100.0     | 2.5         | <b>GFM-8085-100</b>     |
| 85.0  |                                | 90.0  | 98.0      | 100.0     | 2.5         | <b>GFM-8590-100</b>     |
| 90.0  |                                | 95.0  | 103.0     | 100.0     | 2.5         | <b>GFM-9095-100</b>     |
| 95.0  |                                | 100.0 | 108.0     | 100.0     | 2.5         | <b>GFM-95100-100</b>    |
| 100.0 | +0.072                         | 105.0 | 113.0     | 42.5      | 2.5         | <b>GFM-100105-425</b>   |
| 100.0 | +0.212                         | 105.0 | 113.0     | 100.0     | 2.5         | <b>GFM-100105-100</b>   |
| 110.0 |                                | 115.0 | 123.0     | 100.0     | 2.5         | <b>GFM-110115-100</b>   |
| 120.0 |                                | 125.0 | 133.0     | 80.0      | 2.5         | <b>GFM-120125-80</b>    |
| 120.0 |                                | 125.0 | 133.0     | 100.0     | 2.5         | <b>GFM-120125-100</b>   |
| 125.0 |                                | 130.0 | 138.0     | 100.0     | 2.5         | <b>GFM-125130-100</b>   |
| 130.0 |                                | 135.0 | 143.0     | 100.0     | 2.5         | <b>GFM-130135-100</b>   |
| 140.0 | +0.085                         | 145.0 | 153.0     | 100.0     | 2.5         | <b>GFM-140145-100</b>   |
| 150.0 | +0.245                         | 155.0 | 163.0     | 40.0      | 2.5         | <b>GFM-150155-40</b>    |
| 150.0 |                                | 155.0 | 163.0     | 100.0     | 2.5         | <b>GFM-150155-100</b>   |
| 195.0 | +0.100<br>+0.285               | 205.0 | 240.0     | 65.0      | 5.0         | <b>GFM-195205240-65</b> |

<sup>3)</sup> After press-fit. Testing methods ► Page 57



#### Couldn't find your size?

Do you need another length, other dimensions or tolerances? You need a particular design or alternative for your application? Please call us. igus® listens to your needs and provides you a solution very quickly.



#### Even more dimensions from stock

More than 300 dimensions are now available. Search online for your required bearing.

► [www.igus.eu/iglidur-specialbearings](http://www.igus.eu/iglidur-specialbearings)

## Thrust Washer (Form T)

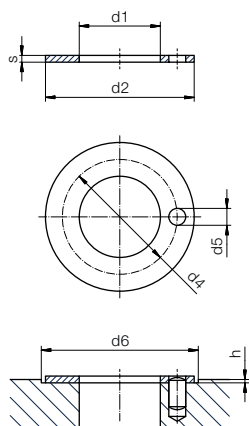
 Order key

Type

Dimensions [mm]

G T M-04 08-005

iglidur® material

Form T

Metric

Inner-Ø d1

Outer-Ø d2

Thickness s

 Dimensions according to ISO 3547-1 and special dimensions

 Imperial dimensions available  
 ► From page 1445

## Dimensions [mm]

| d1    | d2    | s           | d4             | d5               | h            | d6    | Part No.     |
|-------|-------|-------------|----------------|------------------|--------------|-------|--------------|
| +0.25 | -0.25 | -0.05       | -0.12<br>+0.12 | +0.375<br>+0.125 | +0.2<br>-0.2 | +0.12 |              |
| 4.0   | 8.0   | 0.5         | 4)             | 4)               | 0.2          | 8.0   | GTM-0408-005 |
| 4.0   | 9.0   | 0.6         | 4)             | 4)               | 0.3          | 9.0   | GTM-0409-006 |
| 4.0   | 9.0   | 1.6         | 4)             | 4)               | 0.3          | 9.0   | GTM-0409-016 |
| 4.0   | 10.0  | 0.5         | 4)             | 4)               | 0.2          | 10.0  | GTM-0410-005 |
| 4.0   | 11.0  | 0.5 (-0.06) | 4)             | 4)               | 0.2          | 11.0  | GTM-0411-005 |
| 5.0   | 9.5   | 0.6         | 4)             | 4)               | 0.3          | 9.5   | GTM-0509-006 |
| 6.0   | 11.0  | 1.0         | 4)             | 4)               | 0.7          | 11.0  | GTM-0611-010 |
| 6.0   | 12.0  | 1.5         | 4)             | 4)               | 1.0          | 12.0  | GTM-0612-015 |
| 6.0   | 15.0  | 1.5         | 4)             | 4)               | 1.0          | 15.0  | GTM-0615-015 |
| 6.0   | 20.0  | 1.5         | 13.0           | 1.5              | 1.0          | 20.0  | GTM-0620-015 |
| 7.0   | 12.0  | 0.5         | 4)             | 4)               | 0.2          | 12.0  | GTM-0712-005 |
| 7.0   | 13.0  | 0.5         | 4)             | 4)               | 0.2          | 13.0  | GTM-0713-005 |
| 8.0   | 15.0  | 0.5         | 4)             | 4)               | 0.2          | 15.0  | GTM-0815-005 |
| 8.0   | 15.0  | 1.5         | 4)             | 4)               | 1.0          | 15.0  | GTM-0815-015 |
| 8.0   | 18.0  | 1.0         | 4)             | 4)               | 0.7          | 18.0  | GTM-0818-010 |
| 8.0   | 18.0  | 1.5         | 13.0           | 1.5              | 1.0          | 18.0  | GTM-0818-015 |
| 8.0   | 18.0  | 2.0         | 4)             | 4)               | 1.5          | 18.0  | GTM-0818-020 |
| 9.0   | 13.0  | 1.0         | 4)             | 4)               | 0.7          | 13.0  | GTM-0913-010 |
| 9.0   | 18.0  | 1.5         | 13.5           | 1.5              | 1.0          | 18.0  | GTM-0918-015 |
| 10.0  | 17.8  | 0.5         | 4)             | 4)               | 0.2          | 17.8  | GTM-1018-005 |
| 10.0  | 18.0  | 1.0         | 4)             | 4)               | 0.7          | 18.0  | GTM-1018-010 |
| 10.0  | 18.0  | 1.5         | 4)             | 4)               | 1.0          | 18.0  | GTM-1018-015 |
| 10.0  | 18.0  | 2.0         | 4)             | 4)               | 1.5          | 18.0  | GTM-1018-020 |
| 10.0  | 20.0  | 1.5         | 4)             | 4)               | 0.7          | 20.0  | GTM-1020-015 |
| 11.0  | 15.0  | 1.0         | 4)             | 4)               | 0.7          | 15.0  | GTM-1115-010 |
| 11.0  | 27.0  | 0.5         | 4)             | 4)               | 0.2          | 27.0  | GTM-1127-005 |
| 12.0  | 24.0  | 1.5         | 18.0           | 1.5              | 1.0          | 24.0  | GTM-1224-015 |
| 12.2  | 30.0  | 1.5         | 4)             | 4)               | 1.0          | 30.0  | GTM-1230-015 |

4) Design without fixing bore



## Thrust washer

### Dimensions [mm]

| d1    | d2    | s     | d4             | d5               | h            | d6    | Part No.      |
|-------|-------|-------|----------------|------------------|--------------|-------|---------------|
| +0.25 | -0.25 | -0.05 | -0.12<br>+0.12 | +0.375<br>+0.125 | +0.2<br>-0.2 | +0.12 |               |
| 14.0  | 20.0  | 1.5   | 4)             | 4)               | 1.0          | 20.0  | GTM-1420-015  |
| 14.0  | 26.0  | 1.5   | 20.0           | 2.0              | 1.0          | 26.0  | GTM-1426-015  |
| 15.0  | 22.0  | 0.8   | 4)             | 4)               | 0.5          | 22.0  | GTM-1522-008  |
| 15.0  | 19.0  | 0.8   | 4)             | 4)               | 0.5          | 19.0  | GTM-1519-008  |
| 15.0  | 24.0  | 1.5   | 19.5           | 1.5              | 1.0          | 24.0  | GTM-1524-015  |
| 15.0  | 24.0  | 2.75  | 4)             | 4)               | 2.0          | 24.0  | GTM-1524-0275 |
| 16.0  | 28.0  | 1.0   | 4)             | 4)               | 0.7          | 28.0  | GTM-1628-010  |
| 16.0  | 30.0  | 1.5   | 22.0           | 2.0              | 1.0          | 30.0  | GTM-1630-015  |
| 18.0  | 32.0  | 1.5   | 25.0           | 2.0              | 1.0          | 32.0  | GTM-1832-015  |
| 20.0  | 36.0  | 1.5   | 28.0           | 3.0              | 1.0          | 36.0  | GTM-2036-015  |
| 22.0  | 30.0  | 1.5   | 4)             | 4)               | 1.0          | 30.0  | GTM-2230-015  |
| 22.0  | 38.0  | 1.5   | 30.0           | 3.0              | 1.0          | 38.0  | GTM-2238-015  |
| 24.0  | 42.0  | 1.5   | 33.0           | 3.0              | 1.0          | 42.0  | GTM-2442-015  |
| 26.0  | 44.0  | 1.5   | 35.0           | 3.0              | 1.0          | 44.0  | GTM-2644-015  |
| 28.5  | 35.8  | 0.5   | 4)             | 4)               | 0.2          | 35.8  | GTM-2835-005  |
| 28.0  | 48.0  | 1.5   | 38.0           | 4.0              | 1.0          | 48.0  | GTM-2848-015  |
| 32.0  | 45.8  | 1.0   | 4)             | 4)               | 0.7          | 45.8  | GTM-3246-010  |
| 32.0  | 54.0  | 1.5   | 43.0           | 4.0              | 1.0          | 54.0  | GTM-3254-015  |
| 38.0  | 62.0  | 1.5   | 50.0           | 4.0              | 1.0          | 62.0  | GTM-3862-015  |
| 42.0  | 66.0  | 1.5   | 54.0           | 4.0              | 1.0          | 66.0  | GTM-4266-015  |
| 48.0  | 60.0  | 2.0   | 4)             | 4)               | 1.5          | 60.0  | GTM-4860-020  |
| 48.0  | 74.0  | 2.0   | 61.0           | 4.0              | 1.5          | 74.0  | GTM-4874-020  |
| 52.0  | 78.0  | 2.0   | 65.0           | 4.0              | 1.5          | 78.0  | GTM-5278-020  |
| 52.5  | 69.0  | 2.0   | 4)             | 4)               | 1.5          | 69.0  | GTM-52569-020 |
| 62.0  | 78.0  | 2.0   | 4)             | 4)               | 1.5          | 78.0  | GTM-6278-020  |
| 62.0  | 90.0  | 1.0   | 4)             | 4)               | 0.7          | 90.0  | GTM-6290-010  |
| 62.0  | 90.0  | 2.0   | 76.0           | 4.0              | 1.5          | 90.0  | GTM-6290-020  |
| 68.0  | 81.0  | 2.0   | 4)             | 4)               | 1.5          | 81.0  | GTM-6881-020  |
| 78.0  | 114.0 | 1.5   | 4)             | 4)               | 1.0          | 114.0 | GTM-78114-015 |
| 80.5  | 114.0 | 1.5   | 4)             | 4)               | 1.0          | 114.0 | GTM-80114-015 |

4) Design without fixing bore



Even more dimensions from stock

More than 300 dimensions are now available. Search online for your required bearing.

► [www.igus.eu/iglidur-specialbearings](http://www.igus.eu/iglidur-specialbearings)