

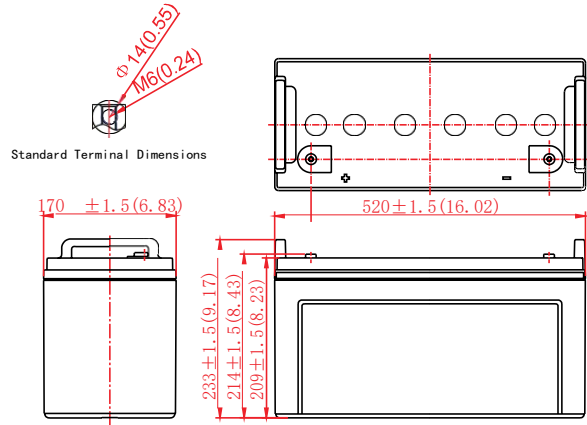

SILICON BATTERY

General Feature

- * Specialize in Solar Accumulation System
- * Excellent Deep-cycle performance
- * 80% DOD is more than 800 cycles
- * Low internal resistance and low self-discharging
- * Operating Temperature:-40·C-70·C
- * Floating Charging Service Life: 10 years



Specification

Normal Voltage	12V
	250Ah @ 10hr to 1.80V/cell @
Weight	25°C (77°F) 71.0kg
Internal Resistance	Approx. 4.0mΩ
	Discharging:- 40°C~70 -40°F~158
Operating Temperature Range	Charging:- 40°C~70°C (-40°F~158°F)
	Storage:- 40°C~50°C (-40°F~122 °F)
Recommended Operating Temperature	15°C~25°C (59°F~77°F)
Floating Charging Voltage	13.5V~13.8V @ 25°C (77°F)
Max Charging Current	75.0A
Equalization Charging Voltage	14.4V~15.0V @ 25°C (77°F)
Self Discharging	Residual Capacity is more than 90% after 90 days (25°C/77°F)
Terminal	M8
Contain Materials	ABS

Cut-off Voltage	Constant Current Discharge Characteristics Unit: A (25°C, 77°F)														
	5M	15M	30M	45M	1h	2h	3h	4h	5h	6h	8h	10h	12h	20h	24h
1.60V	488	263	159	115	93.0	53.4	41.9	32.1	28.8	24.2	18.8	15.6	13.1	8.16	6.81
1.67V	458	254	156	114	92.6	53.1	41.1	32.0	28.5	24.2	18.6	15.5	13.0	8.09	6.75
1.70V	453	249	155	113	91.8	52.7	40.8	31.7	28.2	24.0	18.6	15.3	12.9	8.07	6.75
1.75V	417	240	153	113	90.5	51.3	40.4	31.4	27.9	23.9	18.2	15.2	12.9	8.06	6.75
1.80V	374	225	146	108	88.1	50.9	40.1	31.2	27.2	23.4	18.0	15.0	12.8	7.97	6.74
1.83V	357	206	143	104	84.3	50.3	38.7	29.9	26.3	22.7	17.9	14.4	12.3	7.95	6.63
1.85V	335	200	133	100	81.6	48.3	37.7	29.4	25.7	22.1	17.3	14.3	12.2	7.80	6.57

Cut-off Voltage	Constant Power Discharge Characteristics Unit: W (25°C, 77°F)														
	5M	15M	30M	45M	1h	2h	3h	4h	5h	6h	8h	10h	12h	20h	24h
1.60V	879	497	309	233	189	108	79.4	62.9	53.0	45.8	35.4	29.1	24.5	15.6	13.1
1.67V	846	488	308	231	188	108	78.3	62.7	53.0	45.5	35.1	28.8	24.5	15.6	13.1
1.70V	842	482	308	231	188	108	78.2	62.6	52.2	45.0	35.0	28.7	24.3	15.6	13.1
1.75V	795	479	306	231	185	107	77.4	62.4	52.2	44.9	34.7	28.5	24.2	15.6	13.1
1.80V	729	452	299	225	185	107	77.3	62.3	51.3	44.6	34.5	28.5	24.2	15.6	13.1
1.83V	707	414	296	219	176	106	75.5	60.0	50.3	43.2	34.2	27.8	23.4	15.5	13.0
1.85V	669	404	275	210	171	102	73.4	59.3	49.1	42.3	33.2	27.5	23.1	15.2	12.9

Discharging Characrictic (25°C, 77°F)

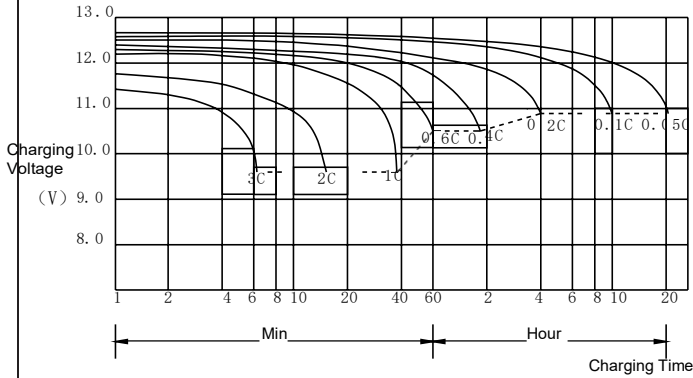

Charging Characteristics Curves

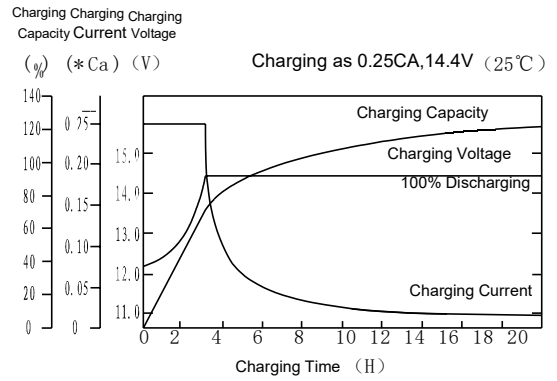

Tempreture Vs Capacity

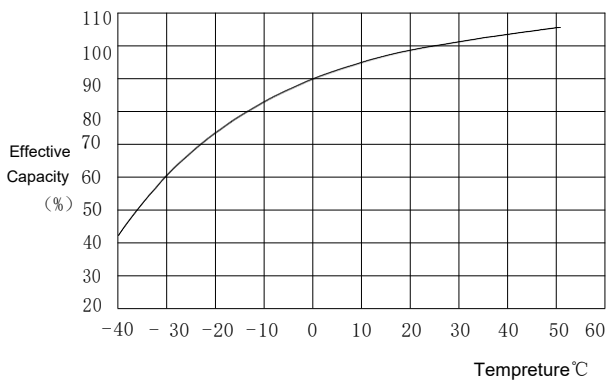

Self-Discharge Characteristics

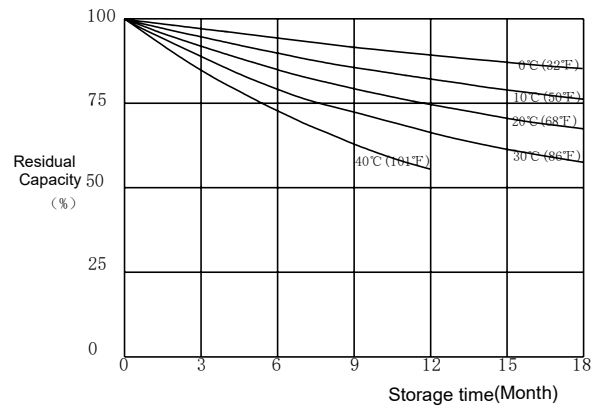

Recycle Life

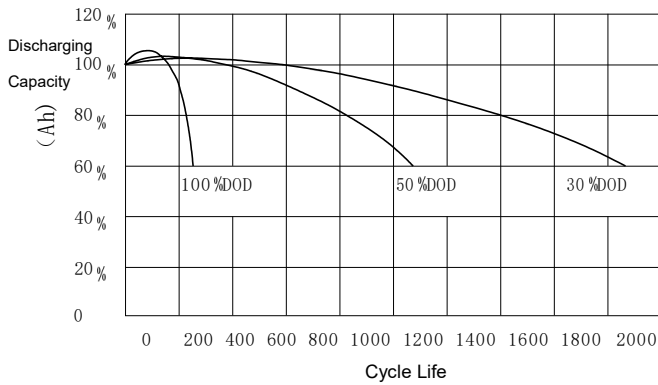

Tempreture VS Float Life

