

# NS-50-1 摺衫檯 Shirt Folding Table



- 本機適合工業摺衫及電熱定型領窩
- 不鏽鋼衫板，能統一每件摺好恤衫尺寸
- 機面的鈕槽把胸前衫鈕傍在中線，使摺好之恤衫左右平衡
- 適合左右手操作，臺面高度可調節，滿足不同操作人員需求
- 本機領型有三角形、圓型、杏型、杏圓型，客戶可選擇其中一種跟機，不選擇領型即默認跟機三角形
- 每種領型配有5個不同尺碼的領模，采用旋轉換模和氣動壓模設計，方便操作

#### 跟機件：

固定摺衫板

#### 選購件：

O-F-10-1 針架連單層物料架  
A632 活動摺衫板  
PT05-09931M 摺衫板轉換座

- Suitable for industrial shirt folding and electric heated collar creasing
- Stainless steel folding plate standardizes the size of folded shirt
- The button trough can guide shirt buttons to the center line, thereby the folded shirt is always symmetric
- It can be used easily regardless of the upper hand, and table height is adjustable, therefore it can satisfy the operation requirement of different people
- Four different shaped collar moulds, i.e. triangular, round, almond and pear, are available; among which user could select one to be supplied. If no selection, triangular mould is defaulted
- For each specific collar shape there are 5 different-sized moulds; which can switch through rotation; pneumatically-operated collar creasing

#### Standard:

Fixed shirt folding plate

#### Options:

O-F-10-1 Pin stand and single-layer material stand  
A632 Adjustable folding plate  
PT05-09931M Shirt folding plate adaptor

**跟機件 Standards:**



5個不同壓模，滿足不同尺寸需求  
5 different-sized moulds cater for different sized collars

固定摺衫板 Fixed Shirt Folding Plate  
大(Big): 394x190(mm)  
小(Small): 368x165(mm)



跟機有大小固定摺衫板各1塊  
One large and one small fixed shirt folding plates are supplied as standard

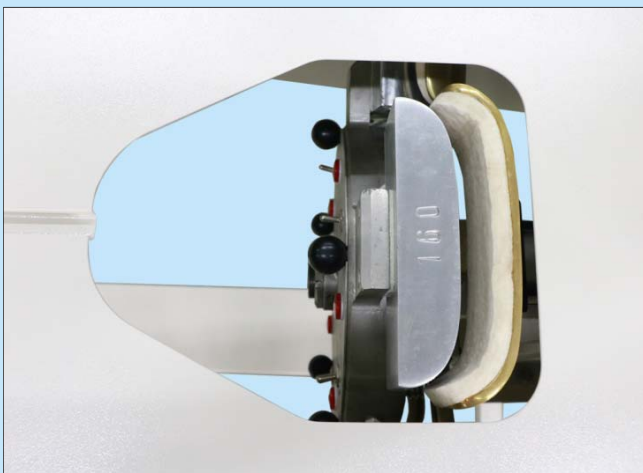

電熱壓模，把領窩定型  
Electric heated mould for collar shaping

**選購件 Options:**

跟機模 Delivered mould:

領闊 Width:  
120mm  
130mm  
140mm  
150mm  
160mm

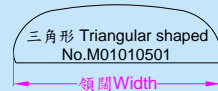

各種領型圖樣  
及領闊規格  
Collar moulds  
of various shapes  
and widths

選購模 Optional mould:

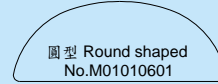

圓型 Round shaped  
No.M01010601

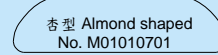

杏型 Almond shaped  
No. M01010701

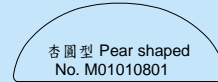

杏圓型 Pear shaped  
No. M01010801

A632  
活動摺衫板  
Adjustable Folding Plate

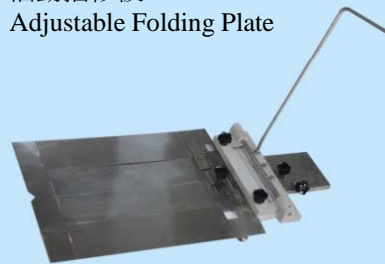

PT05-09931M  
摺衫板轉換座  
Shirt folding  
plate adaptor



以上兩款需配合使用

The above two parts should be used in combination

O-F-10-1針架連單層物料架(選購件)  
Pin stand and single-layer  
stand(Option)

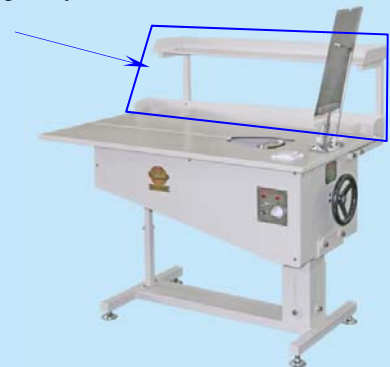

選購針架連單層物料架安裝方法

Assembly method of Pin stand and single-layer material stand

| 型號<br>Model | 電源<br>Power Supply | 總功率(kW)<br>Total Power | 壓縮空氣壓力(kgf/cm <sup>2</sup> )<br>Compressed Air Pressure | 耗壓縮空氣量(L/min)<br>Compressed Air Consumption | 臺面尺寸(mm)<br>Table Size | 臺面高度(mm)<br>Table Height | 淨重(kg)<br>Net Weight | 毛重(kg)<br>Gross Weight | 機身尺寸(mm)<br>Machine Size |
|-------------|--------------------|------------------------|---|---|------------------------|--------------------------|----------------------|------------------------|--------------------------|
| NS-50-1     | 1PH/220V/50Hz      | 0.5                    | 5   | 1   | 1220x610               | 760-860                  | 83                   | 103                    | 1220x620x1330            |



**藝誠(余氏)發展有限公司**  
**Ngai Shing Development Limited**

香港九龍長沙灣永康街52號地下  
G/F., 52 Wing Hong St.,  
Cheung Sha Wan, Kln., Hong Kong.

Tel: (852) 2741 9981, 2742 0078 E-MAIL: info@ngaishing.com  
Fax: (852) 2785 3149 Http://www.ngaishing.com