

**NS-8404P**  
**自動擔桿壓平機**  
**Automatic Shirt Yoke Press**



- 適用襯衫擔桿縫粘合壓熨
- 採用PLC可編程控制器控制及人性化觸摸顯示屏操作
- 垂直加壓方式，壓力分佈均勻，壓熨更平整
- 微壓、輕壓、脈沖、重壓四種壓熨方式供選擇設定，可滿足不同面料需求
- 上模加熱採用兩個獨立數字式溫度控制器控制，溫度控制精確
- 下模可調節，以滿足不同尺碼服裝的需求
- 設有物料夾，物料擺放方便
- 獨立真空抽濕泵，有助衣物定位，冷卻、定型效果佳

**選購件:**

O-J-01-7 吹風冷卻系統(壓縮空氣)

- Suitable for shirt yoke seam fusing and pressing
- Adopt PLC and user friendly touch screen for operation
- Vertical pressing mode provides uniform pressure distribution and smooth effect
- Four pressing modes, i.e. slight press, light press, pulse press and heavy press, are available for selection to cater for different fabrics
- With two independent digital thermostats for accurate temperature control of upper mould
- Lower mould can be adjusted to satisfy different sized garments
- Equipped with material clip to assist fabric laying
- With independent vacuum pump to facilitate garment fixing, cooling and shaping

**Option:**

O-J-01-7 Compressed air blowing cool down system



**選購件 Option:**  
 O-J-01-7 吹風冷卻系統(壓縮空氣)  
 Compressed air blowing cool down system

1. 下模可調校，能滿足不同尺碼衣物需求
2. 設有物料夾，物料擺放方便
3. 優質電器元件
4. 獨立真空抽濕泵，有助衣物定位、冷卻，定型效果佳

1. Adjustable lower mold for different sized garment
2. With material clip to assist fabric laying
3. High quality electric elements
4. Independent vacuum pump for garment positioning, cooling and shaping

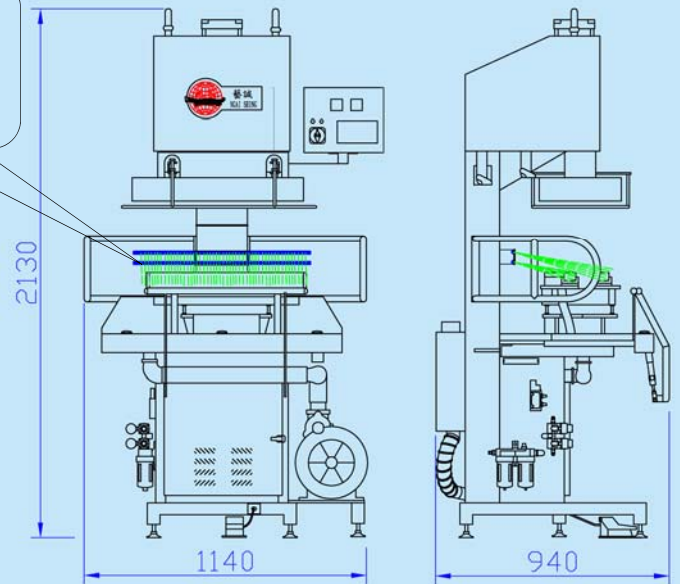

型號 Model	電源 Power Supply	總功率(kW) Total Power	發熱線功率(kW) Heater Power	真空泵功率(kW) Vacuum Pump Power	最大下模長度(mm) Max. Lower Mould Length	壓縮空氣壓力(kgf/cm <sup>2</sup> ) Compressed Air Pressure	耗壓縮空氣量(L/min) Compressed Air Consumption	平均粘合壓力(kgf/cm <sup>2</sup> ) Average Fusing Pressure	機身尺寸(mm) Machine Size
NS-8404P	3PH/380V/50Hz	4.2	3	1.1	690	5	100	2.5	1140x940x2130



**藝誠(余氏)發展有限公司**  
**Ngai Shing Development Limited**

香港九龍長沙灣永康街52號地下  
 G/F., 52 Wing Hong St.,  
 Cheung Sha Wan, Kln., Hong Kong.

Tel: (852) 2741 9981, 2742 0078 E-MAIL: info@ngaishing.com  
 Fax: (852) 2785 3149 Http://www.ngaishing.com