

NS-6050J-1

半自動間領間袖口收料架

Semi-Automatic Collar and Cuff Topstitching Stacker

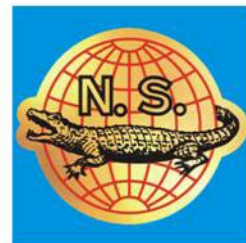

	2	3600RPM	DBx1 #11	

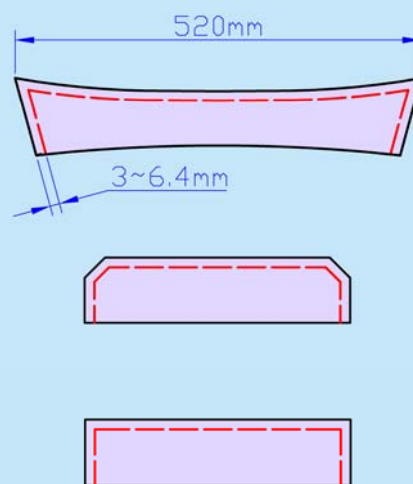

- 適用於車縫襯衫尖領及斜角/直角袖口
- 自適應領線對角線功能，間線邊和角齊整一致
- 裝有收料架，可自動疊放領，整齊美觀且效率高
- 操作簡單，適合生手工人工人操作，一人可操作多台機器(上工序必須處理好領或袖之翻轉、壓熨)

跟機件：

縫紉機(JUKI DDL-8000AS-MS-OBK)

- Suitable for shirt pointed collar and square-/oblique-angled cuff topstitching
- Adaptive collar diagonal function: the edge of the line is consistent with the angle of lines
- With an automatic collector to stack workpieces orderly and enhance efficiency
- So simple is the operation that unskilled worker can handle it with ease; one worker can work on multiple machines(Collar or cuff must be well turned and blocked in last procedure)

Standard:

Sewing head (JUKI DDL-8000AS-MS-OBK)



開始縫紉 Start sewing



縫紉中 In sewing



收料盒 Collecting box

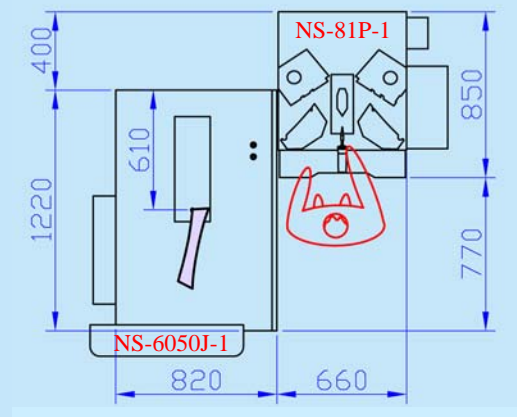

針距 Stitch Length(mm): 1.7

車速 Speed(RPM): 3200

產量 Output(pcs/hr): 領 Collar: 225

六角袖口 Hexagonal cuff: 138

方角袖口 Square cuff: 163

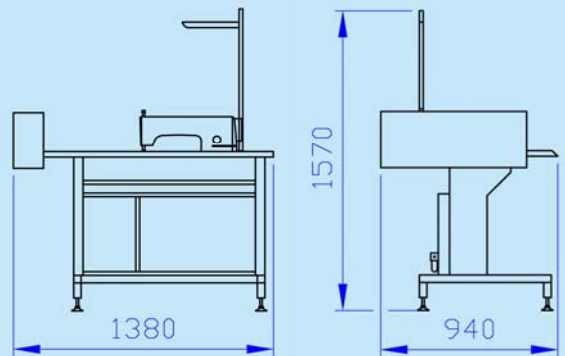

機身尺寸 Machine size

型號 Model	適用衣車頭機型 Applicable Sewing Head Model	電源 Power Supply	總功率 (kW) Total Power	最大轉角值(°) Max. Processable Collar Corner	車縫領最長(mm) Max. Processable Collar Length	間線邊框距離(mm) Stitch-Edge Distance	壓縮空氣壓力 (kgf/cm ²) Compressed Air Pressure	耗壓縮空氣量 (L/min) Compressed Air Consumption	機身尺寸(mm) Machine Size
NS-6050J-1	JUKI DDL-8000A	1PH/220V/50Hz	1	130	520	3~6.4	5	15	1380x940x1570



藝誠(余氏)發展有限公司
Ngai Shing Development Limited

香港九龍長沙灣永康街52號地下
G/F., 52 Wing Hong St.,
Cheung Sha Wan, Kln., Hong Kong.

Tel: (852) 2741 9981, 2742 0078 E-MAIL: info@ngaishing.com
Fax: (852) 2785 3149 Http://www.ngaishing.com