

NS-395E-80 / NS-395G-80
運輸帶式焗爐
Conveyer Belt Type Curing Oven



選購件
Option

NS-395E-80

- 適用於各種衣物布料防皺定型
- 採用循環運風及隔熱保溫設計，能源利用率高
- 可調校風門設計，運風平均，配合三段式漸進加熱系統，溫差小，可達 $\pm 4^{\circ}\text{C}$
- 最高使用溫度 200°C
- 採用數字式溫控系統，溫度精確
- 運輸帶輸送衣物，並可根據不同要求調整運送速度，以達到最佳定型效果

選購件：

預熱系統(蒸汽熱型)
自動收料系統
各種衣架和褲夾
六點溫度監控記錄儀

- Suitable for curing garments of various cloth and wrinkle free treatment
- Air circulation and heat isolation offer high energy utilization rate
- Adjustable air damper, even air distribution, and 3-section progressive heating system jointly limit temperature difference inside oven chamber within $\pm 4^{\circ}\text{C}$
- Max. working temperature: 200°C
- Adopt thermostat to ensure accurate temperature control
- The speed of garment movement, driven by conveyer belt, can be adjusted to suit different fabric so as to achieve the best curing effect

Options:

Preheating system (steam heated type)
Automatic garment unloading system
Various kind of hanger & Trousers Hanger
Six point temperature monitoring recorder



焗衣物時，擋板安裝示意圖
Diagram of baffle plate when curing tops



焗褲子時，擋板安裝示意圖
Diagram of baffle plate when curing trousers

選購件 Options:



日期	時間	炉腔	风道	Ch1	Ch2	Ch3	Ch4	Ch5	Ch6
19/11/12	09:45	134.5	137.7	135.2	134.8	135.8	135.4	136.6	133.5
19/11/12	09:46	134.3	137.3	135.0	134.6	135.4	134.8	136.4	133.1
19/11/12	09:46	135.1	138.1	136.0	135.0	136.0	135.4	136.0	134.8
19/11/12	09:47	134.2	137.7	135.0	134.2	135.4	135.0	136.2	134.2
19/11/12	09:47	134.9	137.9	135.2	134.6	135.6	135.2	136.2	133.8
19/11/12	09:48	135.7	137.1	135.8	135.0	135.6	135.2	136.8	134.6
19/11/12	09:48	134.7	137.1	135.2	134.2	135.2	134.8	135.5	134.2
19/11/12	09:49	134.1	137.0	135.0	134.4	135.2	134.8	136.0	133.6
19/11/12	09:49	135.7	137.7	136.6	135.0	136.0	135.4	136.2	134.4
19/11/12	09:50	134.9	137.7	135.8	134.6	135.8	135.2	136.0	134.6
19/11/12	09:50	135.1	137.3	135.2	134.6	135.2	134.8	136.0	133.8
19/11/12	09:51	134.7	137.1	135.0	134.4	135.6	134.6	135.5	133.8
19/11/12	09:51	134.5	137.3	135.6	134.8	135.8	135.2	135.5	133.6
19/11/12	09:52	135.5	137.5	136.0	135.0	136.0	135.2	135.8	134.4

O-K-08-2 六點溫度監控記錄儀
Six point temperature monitoring recorder

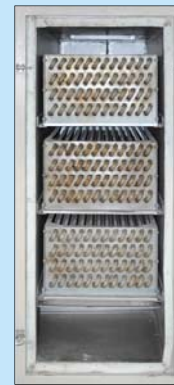

O-K-06-02-S-80 運輸帶焗爐預熱系統-蒸汽
(僅適用於NS-395E-80)
Steam Preheating System for Conveyor Belt Oven (for NS-395E-80 only)



1.O-K-05-1-V1 收料系統 Unloading system
2.O-K-07-1 自動收料掛鉤 Auto unloading hanging hook

型號 Model	加熱方式 Heating Mode	電源 Power Supply	總功率(kW) Total Power	加熱區長度(m) Length of Heating Area	最高溫度(°C) Max. Temp.	最大掛件尺寸(mm) Max. Garment Hanging Height	最小掛距(mm) Min. Distance between Each Piece	可設定加熱時間(min) Adjustable Heating Time	機身尺寸(mm) Machine Size
NS-395E-80	電 electric	3PH/380V/50Hz	120	8.5	200	1200	37.5	4~30	13720x2660x3000
NS-395G-80	瓦斯 gas		11			1350			



藝誠(余氏)發展有限公司
Ngai Shing Development Limited

香港九龍長沙灣永康街52號地下
G/F., 52 Wing Hong St.,
Cheung Sha Wan, Kln., Hong Kong.

Tel: (852) 2741 9981, 2742 0078 E-MAIL: info@ngaishing.com
Fax: (852) 2785 3149 Http://www.ngaishing.com

鏈條總長度 Total chain length: 24800mm

加溫區鏈條長度 Heating zone chain length: 16340mm

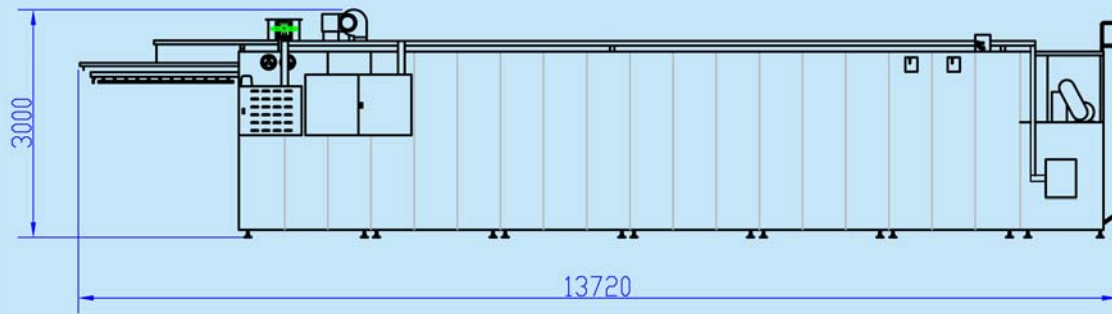
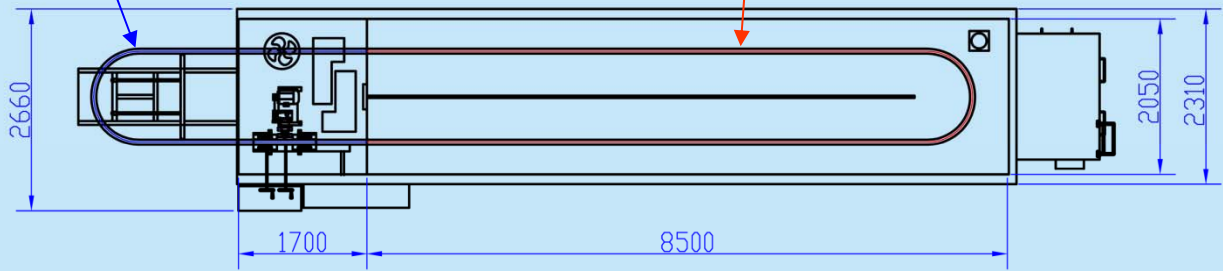

NS-395E-80 標準機型 Standard

選購件 Option
O-K-06-02-S-80

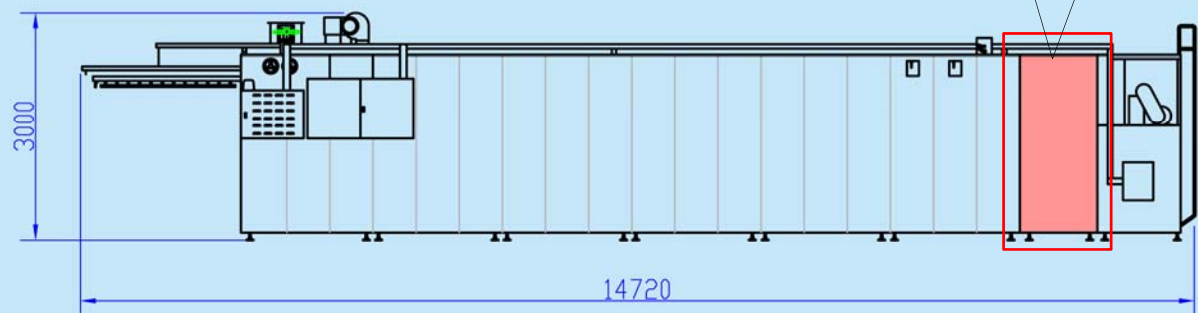



NS-395E-80 標準機型+運輸帶焗爐預熱系統-蒸汽
Standard + Steam Preheating System for Conveyor Belt Oven

焗衣時間(分鐘) Curing Time(Min.)	每小時產量(件) Capacity for Each Hour(pcs)		
	掛距112.5mm(37.5×3) Hanging Distance 112.5mm	掛距150mm(37.5×4) Hanging Distance 150mm	掛距300mm(37.5×8) Hanging Distance 300mm
	NS-395-80	NS-395-80	NS-395-80
8	1065	799	400
10	852	639	320
12	710	533	267
14	609	456	228
16	533	399	200
18	473	355	178
20	426	320	160
22	387	290	145
24	355	266	133
26	328	246	123
28	304	228	114
30	284	213	107

NS-395自動收料系統選購件配置清單

Optional Parts Allocation List of Automatic Unloading System

型號 Model	NS-395-80				
衣物掛距(mm) Garment hanging spacing	75	112.5	150 (標準掛距 Standard)	225	300
O-K-07-1 自動收料掛鉤(pcs) Automatic unloading hanging hook 	330	220	165	110	82
O-K-05-1-V1 收料系統(pcs) Garment unloading system 	1				

備註：以上兩個選購件須按照衣物掛距訂購。以NS-395-80為例：若衣物掛距是75mm，需要訂購 330個O-K-07-1 自動收料掛鉤和1個O-K-05-1-V1 收料系統；如客戶沒有特別說明，建議客戶按照150mm衣物掛距對應的數量來購買，即165個O-K-07-1 自動收料掛鉤和1個O-K-05-1-V1 收料系統。

Remark: The purchased quantities of above two optional parts should be corresponding to specific garment hanging spacing. Taking NS-395-80 for example, 75mm garment hanging spacing needs 330 pcs of O-K-07-1 and 1 pc of O-K-05-1-V1; in case that quantities are not specified by customer, Ngai Shing suggests customer to purchase corresponding quantities of 150mm hanging spacing, i.e. 165 pcs of O-K-07-1 and 1 pc of O-K-05-1-V1.

標準掛距 Standard hanging spacing

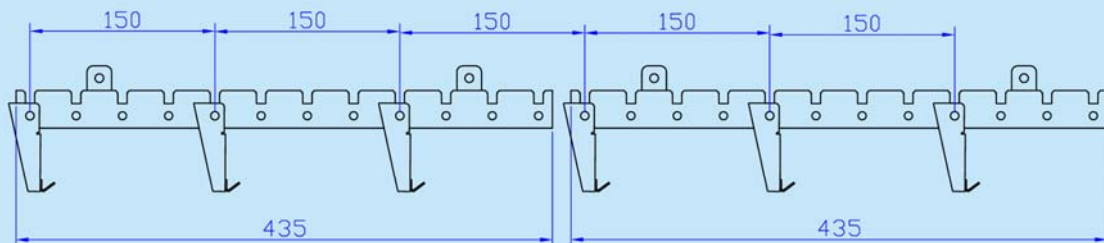

可選掛距1 Optional hanging spacing 1

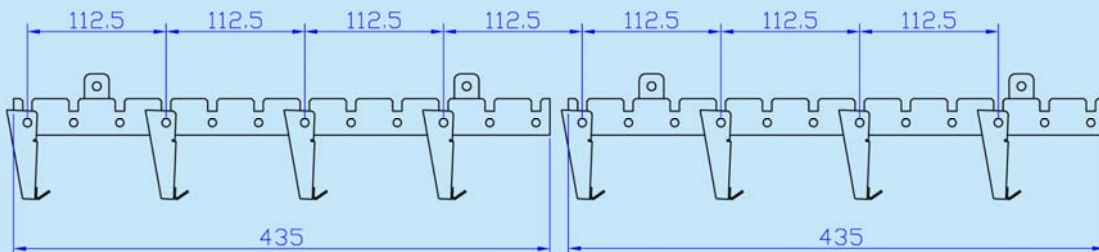

可選掛距2 Optional hanging spacing 2

