

NS-650U-1

氣動摺衫檯連物料架

Pneumatic Shirt Folding Table with Material Stand



摺衫效果
Folded effect

- 適用於工業摺衫及電熱圈領
 - 領模可自動調整，以便配合不同大小，使恤衫立體感更強
 - 採用A632活動摺衫板，尺寸可伸縮調節，適合不同尺碼襯衫(摺衫可調範圍：長260~350mm，寬180~325mm)
 - 檯面的鈕槽把胸前衫鈕傍在中線，使摺好之恤衫左右平衡，搭配摺衫定位尺使用，摺衫效率更高
 - 符合人體工學設計，台面高度及傾斜度可調整
 - 可根據操作習慣及安裝要求，調整電箱和物料架位置
- Suitable for industrial shirt folding and electric heated collar creasing
 - The collar mould could adjust automatically according to shirt size to produce a better 3D effect
 - Adopts A632 movable folding plate with size adjustable to cater for different sized shirts (Folding range: length 260~350mm, width 180~325mm)
 - The table slot provides room for buttons such that the shirt is always symmetric against the center line of the slot; increased efficiency with the aid of shirt locating ruler
 - It conforms to ergonomic design: Table height and slope are adjustable.
 - Electric box and material stand can be mounted on opposite side to adapt to worker's operation habit or to satisfy installation location requirements.

選購件:

杏圓形領模-大、中、小碼

圓形領模-大、中、小碼

三角形領模-大、中、小碼

Options:

Pear Collar – L/M/S

Round Collar – L/M/S

Triangular Collar- L/M/S

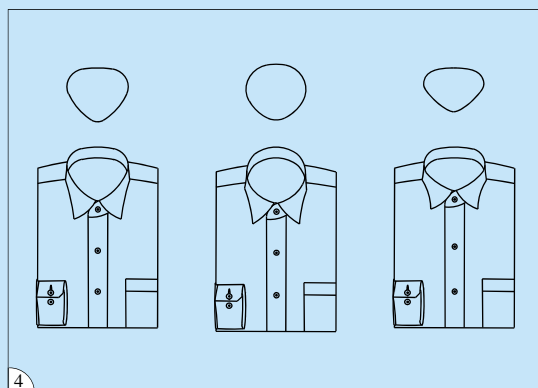
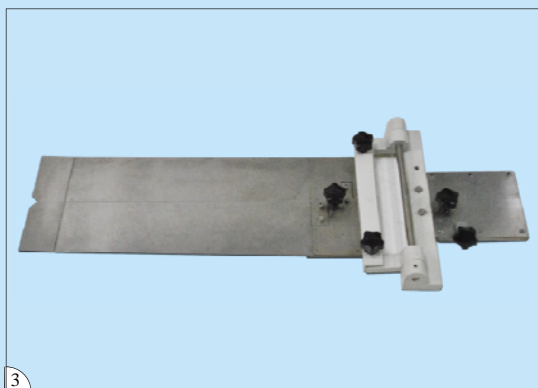
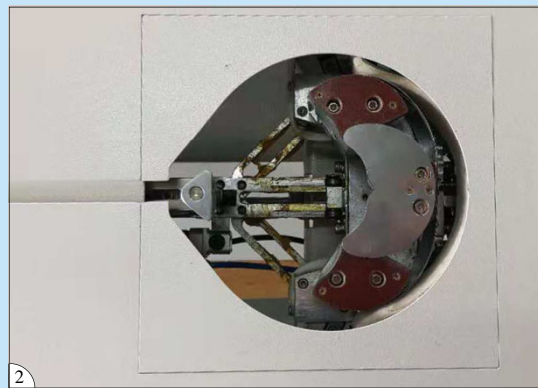
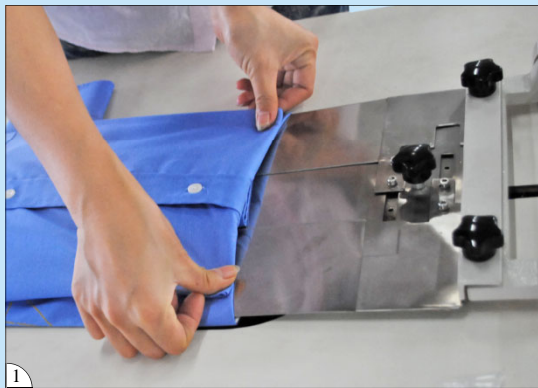

1.工作示意圖

2.跟機模：

(M01010102 杏圓型中碼) 適合14 ½~18"的領型，有圈領及定位功能，使領型立體感更強

3.跟機件：

A632活動摺衫板，可根據襯衫長度及寬度進行相應調節

4.選購件：

三種領型領模：三角型、杏圓型和圓型(大、中、小碼)供選購

5 領模規格及編號

1. In working

2. **Standard Mould:**

(M01010102 Pear shaped & middle sized)
Suitable for collar of width between 14 ½~18". It fixes and creases collar to enhance 3D effect of collar shape

3. **Standard Accessory:**

A632 adjustable shirt folding plate (its length and width could be adjusted to meet requirement of different shirts)

4. **Options:**

3 configurations of collar moulds for selection: triangular shaped, round shaped and pear shaped moulds (for large, middle, small sized shirts)

5. Collar mould specification and code

模樣 Mould Configuration	名稱 Description	規格 Specification	編號 Code
	杏圓型領模 Pear shaped collar mould	Large 大碼(18"~23")	M01010101
		Middle 中碼(14 1/2"~18")	M01010102
		Small 小碼(12"~14 1/2")	M01010103
	圓型領模 Round shaped collar mould	Large 大碼(18"~23")	M01010201
		Middle 中碼(14 1/2"~18")	M01010202
		Small 小碼(12"~14 1/2")	M01010203
	三角型領模 Triangular shaped collar mould	Large 大碼(18"~23")	M01010301
		Middle 中碼(14 1/2"~18")	M01010302
		Small 小碼(12"~14 1/2")	M01010303



標準安裝位置
Standard Layout



可根據習慣更換操作方向
Alternative Layout to suit
operating habit

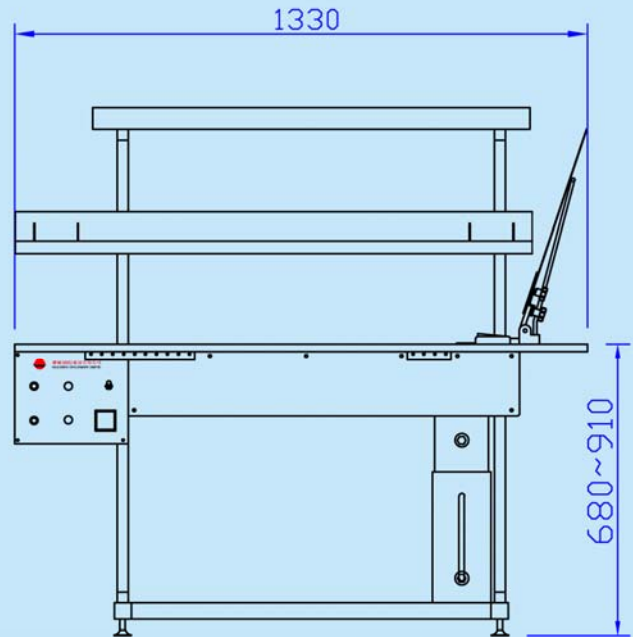
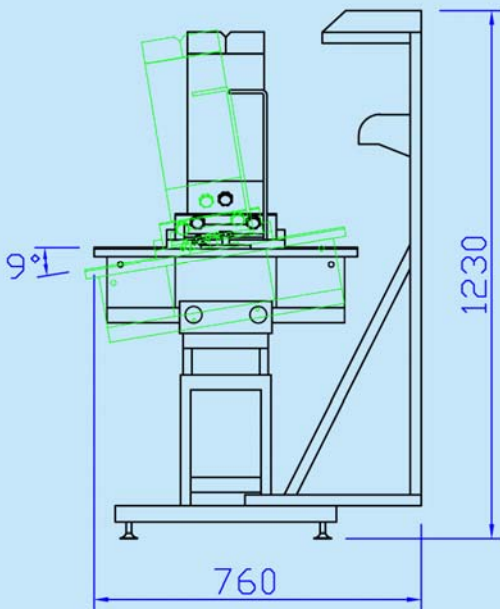

型號 Model	電源 Power Supply	總功率(kW) Total Power	壓縮空氣壓力(kgf/cm ²) Compressed Air Pressure	耗壓縮空氣量(L/min) Compressed Air Consumption	檯面尺寸(mm) Table Size	檯面高度(mm) Table Height	淨重(kg) Net Weight	毛重(kg) Gross Weight	機身尺寸(mm) Machine Size
NS-650U-1	1PH/220V/50Hz	0.35	5	4	1330 x 610	680~910	88	108	1330x760x1230



藝誠(余氏)發展有限公司
Ngai Shing Development Limited

香港九龍長沙灣永康街52號地下
G/F., 52 Wing Hong St.,
Cheung Sha Wan, Kln., Hong Kong.

Tel: (852) 2741 9981, 2742 0078 E-MAIL: info@ngaishing.com
Fax: (852) 2785 3149 Http://www.ngaishing.com