

**NS-6002-1**

**襯衫前幅鈕筒切樸器連收料架**

**Shirt Front Box Placket Interlining Cutting Device  
with Stacker**

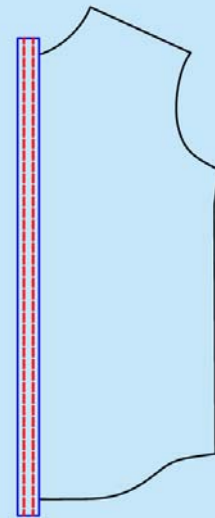
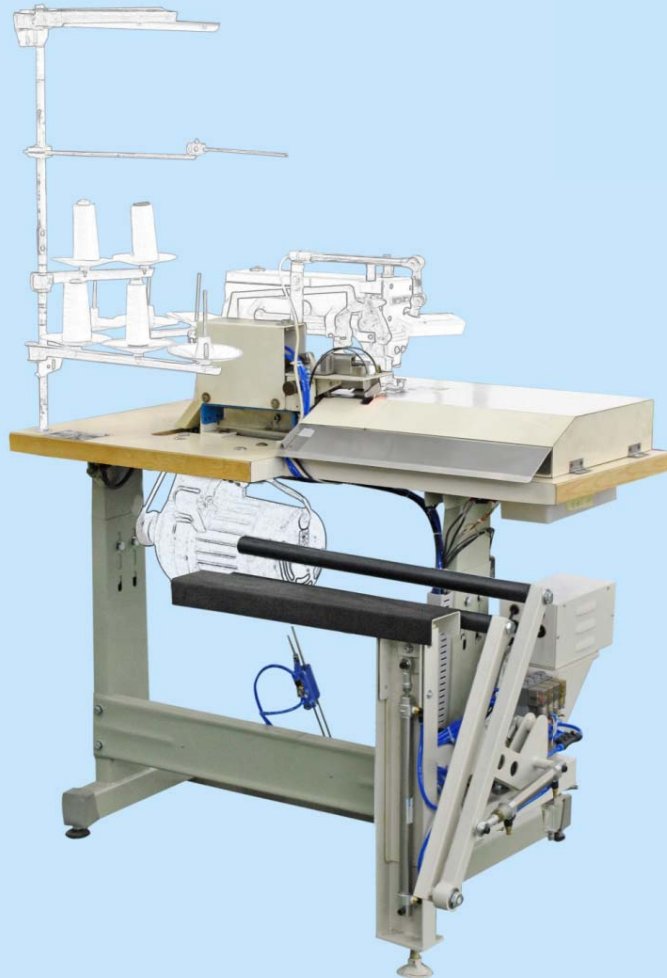

- 適用於配合拉筒車車縫男女裝前幅鈕筒
- 電眼感應自動切筒，並自動將裁片整齊疊好，減少人手收料工序，大大提高工作效率
- 撥布桿自動撥布
- 疊布架能提升，使操作者能在原位取裁片
- 結構緊湊美觀，易於安裝、清潔及維護
- 用戶需自備衣車頭

**跟機件：**

檯板及檯面吹風盒、腳架

**選購件：**

A804 拖輪、A902-4 上送機器

- Suitable for assisting placket machine in sewing men's and ladies' shirt placket
- Electric eye aided automatic placket cutting; finished pieces will be automatically stacked neatly, therefore, less manual work, higher efficiency
- Automatically swipe fabric over horizontal bar
- Horizontal bar can lift up for operator to collect finished pieces while remaining seated
- Smart and compact design, easy to install, clean and maintain
- Users need prepare sewing head

**Standards:**

Table & Air Blowing Box, Stand

**Option:**

A804 Puller, A902-4 Top Tape Feeder

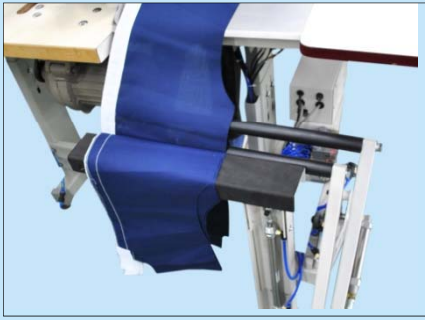

夾布桿夾布  
Fabric clamping





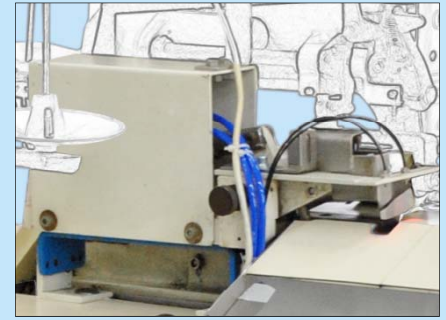

原位取料  
Collect material while remaining seated

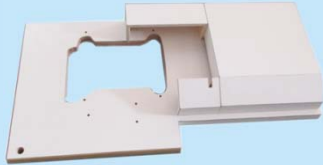

電眼感應裝置連切刀  
Electric eye sensing device with cutter

**跟機件：**  
**Standards:**

**選購件：**  
**Option:**

<p>吹風檯板 Table top with air blowing</p> 	<p>A3001-1 L-型車腳架 A3001-1 L-shaped stand</p> 	<p>A804 拖輪 A804 Puller</p> 	<p>A902-4 上送機器 A902-4 Top Tape Feeder</p> 
---	---	--	--

收料架流程圖 Flow chart of working process :

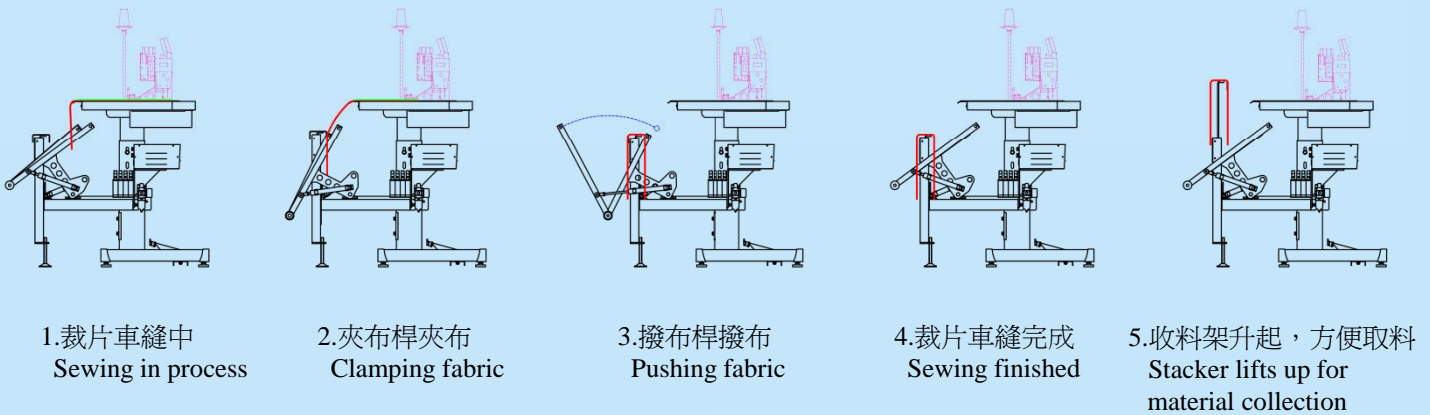

型號 Model	適用衣車頭品牌 Brand of Applicable Sewing M/c	適用衣車頭機型 Model of Applicable Sewing M/c	電源 Power Supply	總功率(kW) Total Power	壓縮空氣壓力(kgf/cm <sup>2</sup> ) Compressed Air Pressure	耗壓縮空氣量(L/min) Compressed Air Consumption	淨重(kg) Net Weight	機身尺寸(mm) Machine Size
NS-6002-1	關西 KANSAI	DFB1404PSF	1PH/220V/50Hz	0.05	5	10	65	1165×1050×1000
	雅滿桃 YAMATO	VM1804PR-NG-102						



**藝誠(余氏)發展有限公司**  
**Ngai Shing Development Limited**

香港九龍長沙灣永康街52號地下  
G/F., 52 Wing Hong St.,  
Cheung Sha Wan, Kln., Hong Kong.

Tel: (852) 2741 9981, 2742 0078 E-MAIL: info@ngaishing.com  
Fax: (852) 2785 3149 Http://www.ngaishing.com