

NS-2410 輥熨機 Rotary Pressing Machine

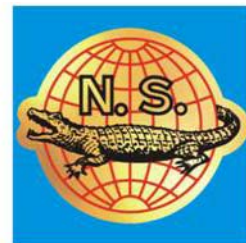

可安裝各種蝴蝶作摺熨用
Can be mounted with various folders
for folding purpose

- 適用於折疊和壓熨三尖側
- 自動運輸帶平衡系統，滾筒運輸帶式設計，操作簡易
- 壓力可調，可選購安裝各種蝴蝶製作不同風格的三尖側
- 採用優質紅外線恆溫針，溫度控制精確，摺熨效果佳
- 工作寬度: 400mm
- 最高設計溫度: 200°C

選購件：

F537、F538、F539、F540、F541、F543 系列蝴蝶
O-C-08-01 自動收料系統

- Suitable for folding and pressing triangular sleeve placket
- Automatic conveyor belt balancing system, roller conveyor belt design, easy operation
- Adjustable pressing force; various optional folders can be mounted to produce sleeve plackets of different styles
- With high-quality infrared thermostat sensor, accurate temperature control and superb folding and pressing effect
- Working width: 400mm
- Max. design temperature: 200°C

Options:

Folders of F537, F538, F539, F540, F541, F543
O-C-08-01 Automatic Collecting System

選購件Options:



F537摺袋貼蝴蝶
Plait Folder



F538 三尖側貼蝴蝶
Triangular Sleeve Placket Folder



F539四方摺貼蝴蝶
Rectangular Sleeve Placket Folder



F540三尖側貼蝴蝶
Triangular Sleeve Placket Folder



F541三尖側貼對條蝴蝶
Triangular Sleeve Placket Folder



F543摺袋貼蝴蝶
Plait Folder



O-C-08-01 自動收料系統
Automatic Collecting System

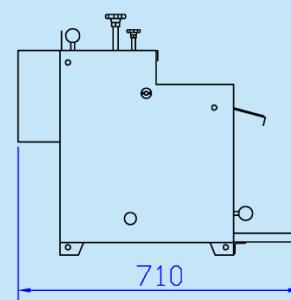
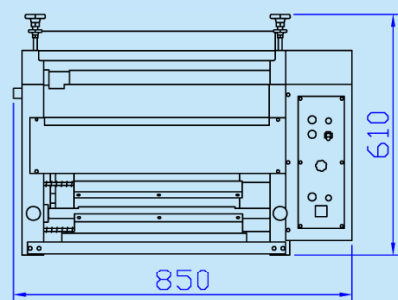

機身外形圖(單位: mm)
Machine Size Illustration(unit: mm)

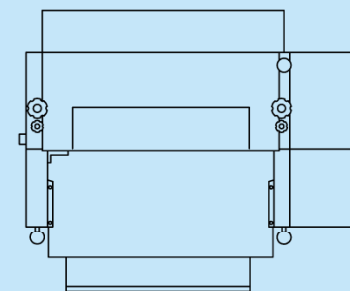

型號 Model	電源 Power Supply	總功率(kW) Total Power	發熱線功率(kW) Heater Power	工作寬度(mm) Working Width	最高設計溫度(°C) Max. Design Temp.	機身尺寸(mm) Machine Size
NS-2410	1PH/220V/50Hz	2.7	2.5	400	200	850x710x610



藝誠(余氏)發展有限公司
Ngai Shing Development Limited

香港九龍長沙灣永康街52號地下
G/F., 52 Wing Hong St.,
Cheung Sha Wan, Kln., Hong Kong.

Tel: (852) 2741 9981, 2742 0078 E-MAIL: info@ngaishing.com
Fax: (852) 2785 3149 Http://www.ngaishing.com