

**NS-2801-3-S / NS-2801-5.5-S**  
**節能乾衣機**  
**Energy Saving Drying Tumbler**



NS-2801-3-S

- 適用於烘乾各種棉織、牛仔、梭織、針織、化纖等衣物
- 節能環保型設計，回收利用乾衣後排風余熱和蒸汽冷凝水余熱，有效利用熱能，降低生產成本，減少污染
- 備自動除塵裝置，降低對空氣質量造成的負面影響
- 采用全新的分段式加溫模式，有效地縮短了乾衣時間，顯著提高乾衣效率
- 機頂設有氣動冷風門，通過控制冷風對內膽衣物進行冷卻從而確保乾衣質量
- 采用PLC及人性化觸摸顯示屏控制，自動化程度高，使用簡單、方便
- 采用變頻控制系統，內膽轉動可實現變頻調速，可定時正、反轉動，使衣物均衡滾動
- 設有手動小門，方便檢測
- 機身可傾斜倒料，減少人力
- Suitable for drying garments made of various fabrics such as cotton, jeans, woven fabric, knitted fabric, synthetic textile, etc.
- Energy saving and eco-friendly design, the hot air exhausted from inner drum and hot condensed water from heat exchanger is efficiently recycled so as to save energy and minimize pollution
- Equipped with automatic dust collecting device, which minimizes negative impact to the air quality
- Adopt step heating mode to shorten the drying time and improve drying efficiency
- Pneumatic air damper on machine top controls the flow rate of fresh air going into heating system so as to ensure the drying quality
- Adopt PLC and user friendly touch screen for operation, highly automated and easy to operate
- With variable frequency drive for variable speed control, inner drum can rotate clockwise or anti clockwise according to the preset time so as to make the garment evenly distributed during rotation
- The equipped manual small door is convenient for drying status checking
- The machine body can tilt forward for faster unloading so as to save labor



機身傾斜倒料  
Machine body tilting for garment unloading



自動除塵箱  
Automatic dust collecting device

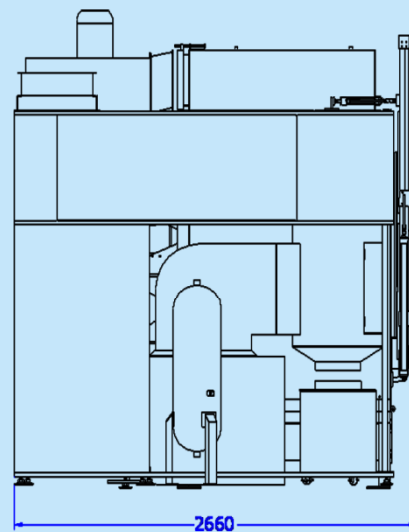
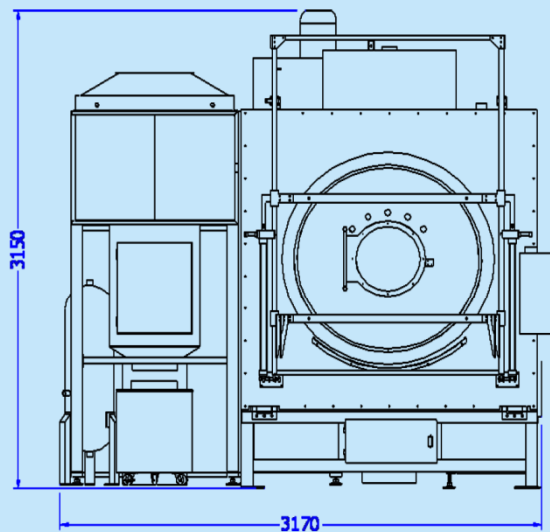

NS-2801-3-S

型號 Model	NS-2801-3-S	NS-2801-5.5-S
內膽容積 (m <sup>3</sup> ) Inner Drum Capacity	3	5.5
電源 Power Supply	3PH/380V/50Hz	3PH/380V/50Hz
總功率 (kW) Total Power	6.7	13.5
風機功率 (kW) Fan Power	2.2+2.2	2.2+5.5
內膽馬達功率 (kW) Inner Drum Motor Power	2.2	5.5
蒸汽壓力 (kgf/cm <sup>2</sup> ) Steam Pressure	3~5	3~5
耗蒸汽量 (kg/hr) Steam Consumption	75~120	137~220
壓縮空氣壓力 (kgf/cm <sup>2</sup> ) Compressed Air Pressure	5	5
耗壓縮空氣量 (L/min) Compressed Air Consumption	25	50
內膽轉速 (RPM) Rotation Speed of Inner Drum	5~27	5~27
內膽尺寸 (mm) Inner Drum Size	Ø1778 x 1194	Ø1880 x 1910



**藝誠(余氏)發展有限公司**  
**Ngai Shing Development Limited**

香港九龍長沙灣永康街52號地下  
G/F., 52 Wing Hong St.,  
Cheung Sha Wan, Kln., Hong Kong.

Tel: (852) 2741 9981, 2742 0078 E-MAIL: info@ngaishing.com  
Fax: (852) 2785 3149 Http://www.ngaishing.com

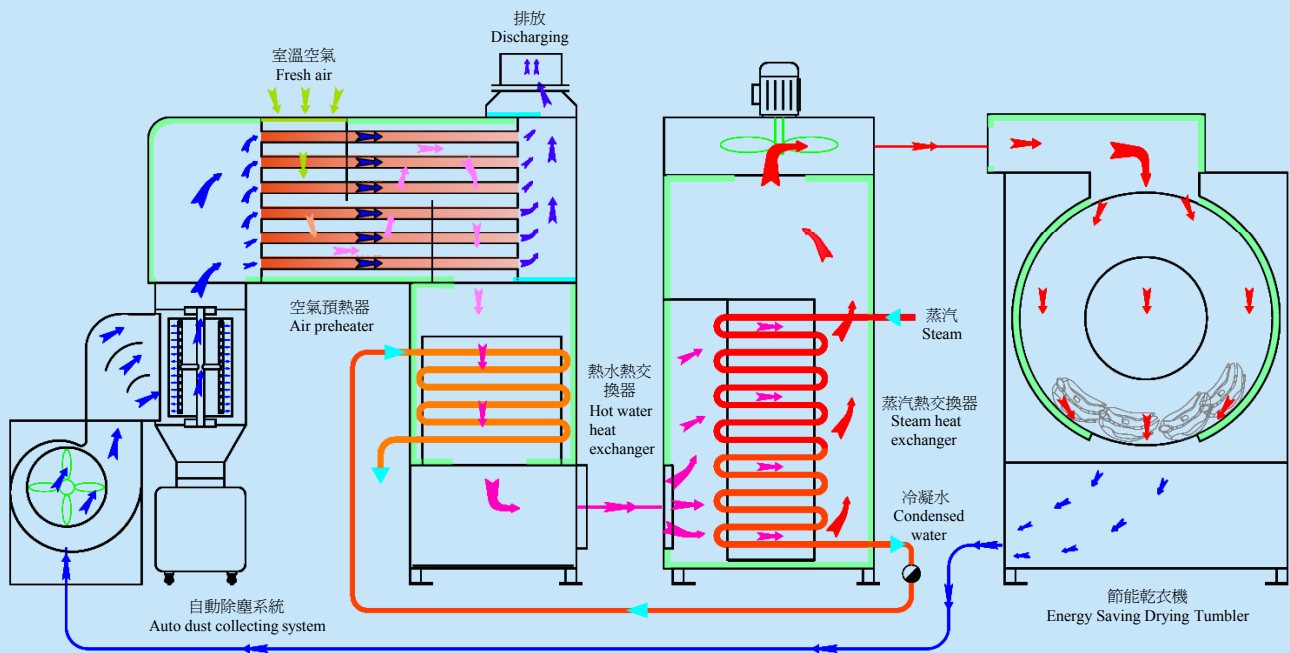

乾衣機工作原理圖  
Working principle diagram of drying tumbler

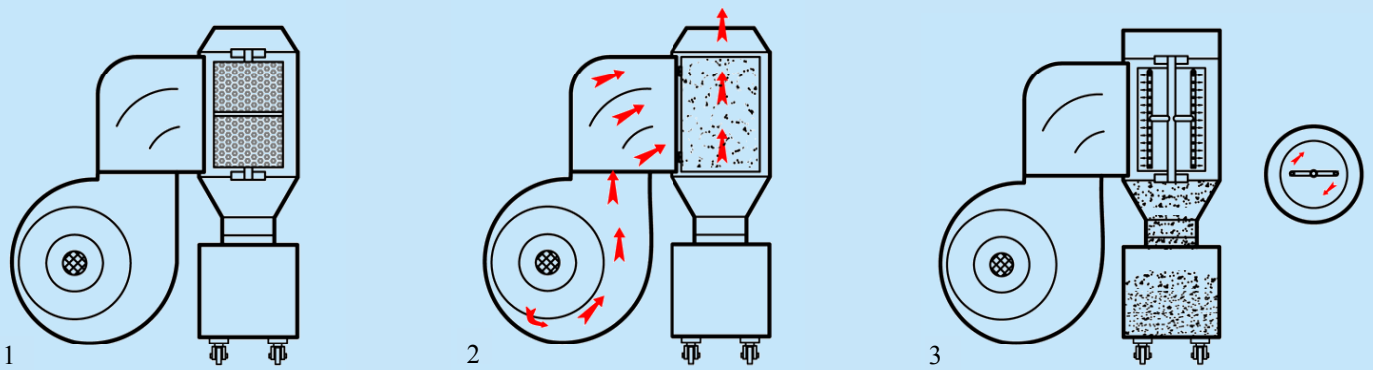

自動環保除塵系統工作原理  
Working principle of environment-friendly automatic de-dusting & filtering system