

# NS-6068J-A 自動襯衫貼袋機 Automatic Shirt Pocket Setter

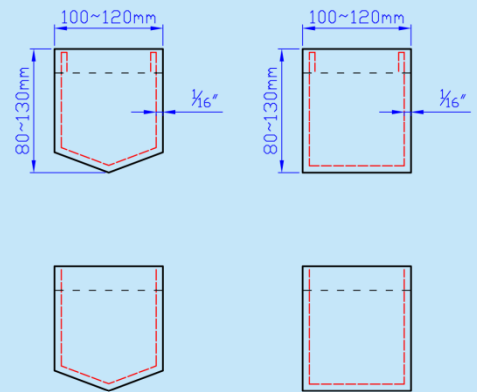

	2	3200RPM	DB x 1 #12	



- 適用於自動縫製襯衫口袋，先自動折疊口袋，然後自動縫製
- 採用PLC可編程控制器控制及人性化觸摸顯示屏，操作方便快捷
- 可根據工藝要求更換摺袋模具
- 雙工位設計，可同時擺料與車縫，提高工作效率
- 自動收料裝置，收料整齊美觀
- 車縫工序自動化，適合非熟練工人操作，每小時可完成240個口袋

#### 跟機件：

縫紉機(JUKI DDL-9000B-SS-OB)

M22110101 不銹鋼三尖襯衫袋模

#### 選購件：

M22110201 不銹鋼四方襯衫袋模

- Suitable for automatic shirt pocket sewing. Pockets are folded first and then sewn automatically
- Adopt PLC and user-friendly touch screen for operation, fast and easy
- Pocket folding template can be changed according to process requirement
- Dual-station design enables material laying and sewing to be performed efficiently at the same time
- With automatic collecting device to arrange finished work pieces neatly
- The whole process of sewing is so automated that even unskilled operator can handle it with output 240 pockets per hour

#### Standards:

Sewing head(JUKI DDL-9000B-SS-OB)

M22110101 Stainless steel triangular bottomed shirt pocket template

#### Option:

M22110201 Stainless steel square bottomed shirt pocket template



1.擺放前幅裁片  
Laying the cut piece of front



2.擺放口袋裁片(免燙)  
Laying the cut piece of pocket(iron-free)

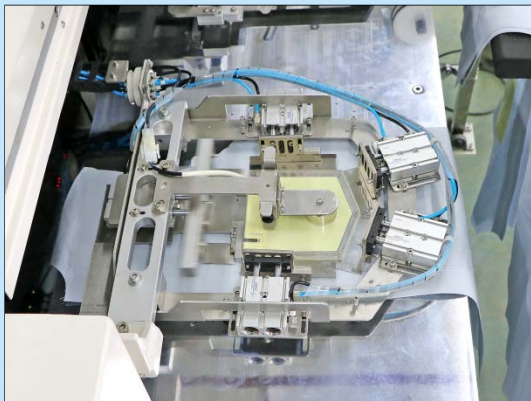

3.機器自動折袋  
Automatic pocket folding by machine

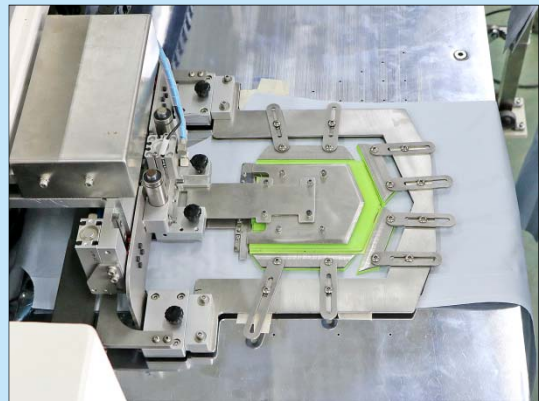

4.折袋完成，準備送入車縫工序  
Pocket folding finished, ready for being conveyed to sewing station



5.機器自動貼袋車縫，同時擺放下件裁片  
Automatic pocket sewing while another cut piece being placed

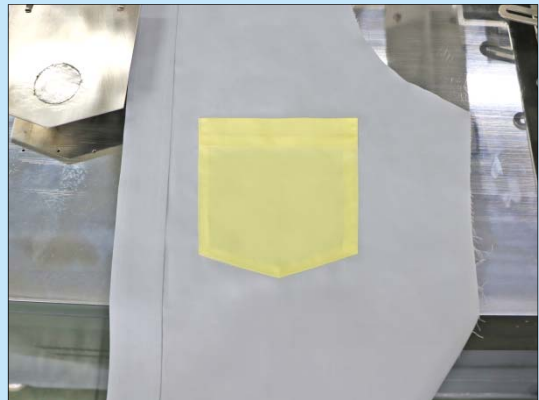

6.貼袋完成效果  
Appearance after pocket sewing

型號 Model	適用衣車頭機型 Applicable Sewing Head Model	電源 Power Supply	總功率(kW) Total Power	車縫至袋邊距離 (inch) Stitch-Edge Distance	針距長度 (mm) Stitch Length	裝袋最大尺寸 (mm) Max. Pocket Size	裝袋最小尺寸 (mm) Min. Pocket Size	壓縮空氣壓力 (kgf/cm <sup>2</sup> ) Compressed Air Pressure	機身尺寸(mm) Machine Size
NS-6068J-A	JUKI DDL-9000B-SS-OB	1PH/220V/50Hz	1.25	1/16	1.4~2.5	120×130	100×80	5	2050×1280×1690



**藝誠(余氏)發展有限公司**  
**Ngai Shing Development Limited**

香港九龍長沙灣永康街52號地下

G/F., 52 Wing Hong St.,

Cheung Sha Wan, Kln., Hong Kong.

Tel: (852) 2741 9981, 2742 0078

E-MAIL: info@ngaishing.com

Fax: (852) 2785 3149

Http://www.ngaishing.com